



## DOMESTIC USE



*ANTI-FREEZE FOR PIPING  
ANTI-FREEZE FOR RAMPS  
ANTI-FREEZE FOR GUTTERS*

page

192

# Heating Cables



## INDUSTRIAL USE



*MCA  
MCA-I-GF  
MCA-I-FF*

204



## HOME COMFORT USE



*FOR FLOORING  
REAR-MIRROR  
FOR CEILINGS*

214



# Heating cables

Heating cables are used for frost protection of pipes, tanks, ramps and walkways, gutters, etc., or for maintaining process temperatures, especially in industrial environments.

There are 2 types:

- **CONSTANT POWER CABLES**, in which the heating element is the conductor through which the current passes, and serves as filament.
- **SELF-REGULATING CABLES**, whose heating element is the conductive core, powered by 2 conductors.

## CONSTANT POWER CABLES

Raytech cables are composed of 2 conductors that are shielded and in the case of Stop Ice (see pg. 194) are supplied with a suitable thermostat for anti-freeze maintenance.

### ADVANTAGES

#### CONSTANT POWER CABLE

- Ready for use, without requiring the installation of accessories.
- Already equipped with a thermostat, in the case of Stop Ice.
- Completely reliable.





## SELF-REGULATING HEATING CABLES

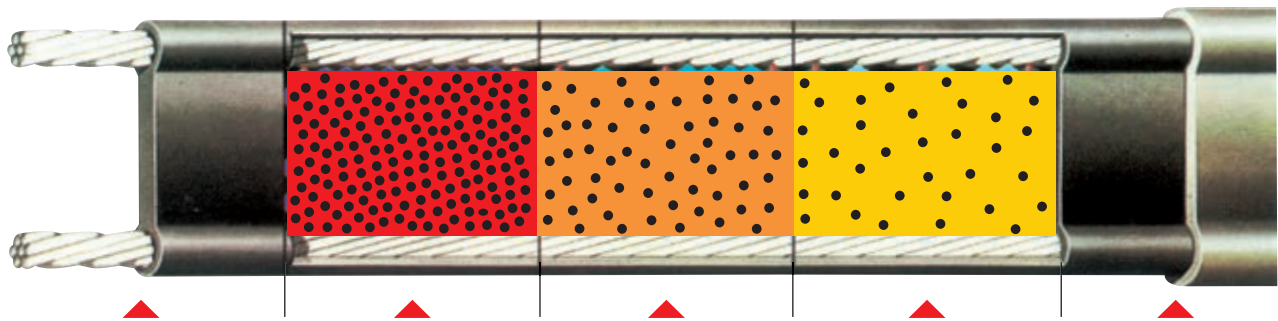

The cable will never become overheated and burn, as it is self-protecting. There is also no need for a thermostat.

Almost all the contacts are interrupted by microscopic dilatation of the core at very high temperatures. The electrical resistance becomes very high and energy output is virtually nil.

The core dilates microscopically in the hotter parts, breaking some of the electrical contacts. As the electrical resistance increases energy output is reduced until a thermal balance is reached between heat loss in the pipes and the heat produced by the cable.

The core contracts microscopically when the heating cable is cold and the graphite forms numerous joints between the conductors. The passage of the current generates heat.

The graphite particles form numerous parallel joints between the two copper conductors.

### The self-regulation technology and the parallel circuit present the following advantages:

- The heating cables can be cut at the right length, jointed and terminated on site.
- They can be supplied at 230 V without transformers.
- They can be overlapped without over heating risks.
- They reduce automatically their power output as the required temperature is reached.
- They are easy designed and can be easily handled on site.

### ADVANTAGES

#### SELF-REGULATING HEATING CABLES

- A reduction in overall installation costs
- Reduction in operating cost
- Very easy to install
- Simple design
- Uniform temperature
- Complete reliability



# DOMESTIC USE

## Anti-freeze for Piping

CONSTANT POWER



### Stop Ice

Constant power anti-freeze kit complete with thermostat and plug



### Linus

Self-adhesive thermal insulating tape



### Stop Ice Plus

Constant power anti-freeze kit complete with thermostat, connection plug and insulation tape

## Anti-freeze for Ramps

CONSTANT POWER



### Easy Cable

Constant power heating cable for access ramps to boxes, walkways, etc.



### Easy Ramp

Heating mat

SELF-REGULATING



### MCA Ramp

Self-regulating heating cable for tracing ramps and stairways



SELF-REGULATING



MCA

Self-regulating cable for anti-freeze use or for maintaining temperatures for general use



MCA Compact

Compact size self-regulating cables for use as anti-freeze or to maintain temperature



Ice Killer

Cut and install self-regulating cable kit, complete with connection side and termination kit

# Anti-freeze for Gutters

CONSTANT POWER



Easy Frost

Constant power heating cable for roofs, gutters and downpipes

SELF-REGULATING

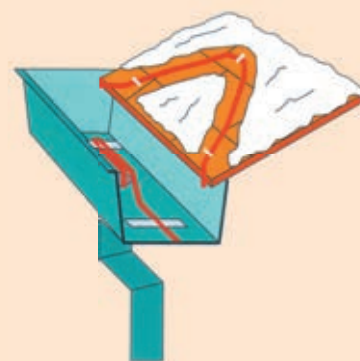
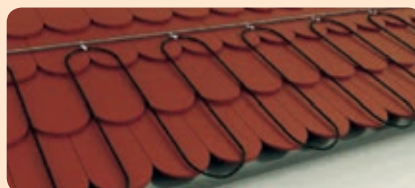

MCA 8

Self-regulating cable for tracking roofs, gutters and/or downpipes



## ANTI-FREEZE FOR PIPING

To keep pipes, tanks, basins, valves and taps, meters, etc. from freezing. Available both in the constant power and in the self-regulating versions.



**Power:** 12 W/m  
**Power supply:** 230 V – 50 Hz  
**Cable dimensions:** ~ 5x7 mm  
**Min. installation temperature:** +5°C  
**Max. working temperature:** +70°C  
**Heating cable type:**  
 2 conductors, screened cable  
**Insulation:** XLPE  
**External sheath:** PVC  
**Min. bending radius:** 3,5 D  
**Protection degree:** IP X7  
**Marking:** CE



Integrated Bimetal Thermostat  
(ON + 3°C - OFF +10°C)



Complete Connections  
and power cord  
(1,5 m - 3 x 0,75 mm<sup>2</sup>)

## Stop Ice

**Constant power** anti-freeze kit complete with thermostat and plug.

Raytech Stop Ice is an innovative pre-assembled kit consisting of a constant wattage heating cable of 12 W/m, complete with contact thermostat (installed on the end of the heating cable) and power cable with plug. Stop-Ice is particularly suitable for frost protection, and prevention of possible damages caused by low temperatures on pipes, valves, faucets, water meters, troughs, bowls and small tanks.

- Easy and quick to install
- No need for any external temperature control system, thanks to its built-in thermostat
- Low energy consumption

Product	Power (W/kit)	Specific power (W/m)	Length (m)
Stop Ice 2/12	24	12	2
Stop Ice 5/12	60	12	5
Stop Ice 10/12	120	12	10
Stop Ice 18/12	216	12	18

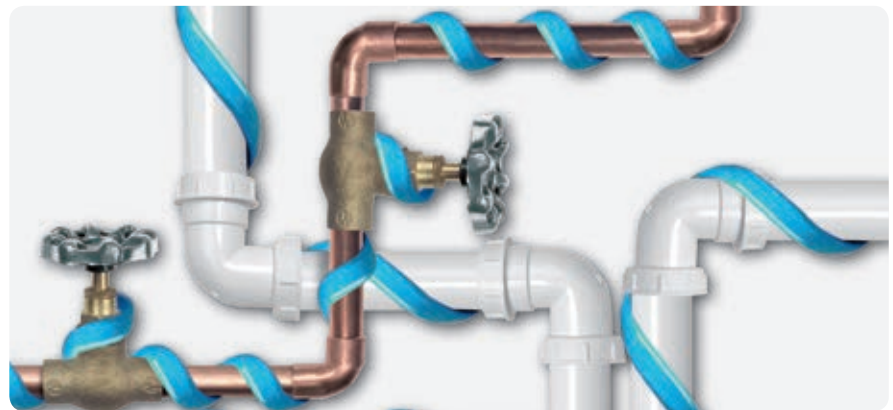

# Linus

Self-adhesive thermal insulating tape.

To offer a complete solution in the field of electrical tracking, Raytech has developed a new product, LINUS, an insulation tape to maintain temperature. The product is a closed-cell expanded synthetic rubber, low thermal conductivity and extremely flexible tape. The rubber tape is coupled with an aluminium sheet to protect against tearing, for greater resistance to perforation and higher tensile resistance. It also protects very well against UV radiation. The tape is self-adhesive for easy application on tracked pipes. The closed cells and the special material type give the tape very high insulating properties and optimal behaviour in the presence of condensation.

Product	Width (mm)	Thickness (mm)	Length (m)
LINUS	50	3	10
	Pipe Ø ¾" (DN 20)	Pipe Ø 1" (DN 25)	Pipe Ø 1 ¼" (DN 32)
LENGTH OF PIPE I can insulate with 1 LINUS tape 50% overlapped	2,2 m	1,9 m	1,6 m



50 mm      3 mm



Density: 0,7  
 Temperature range: -50°C -105°C  
 Coefficient of thermal conductivity (λ): 0,039 W/mK a 50°C  
 Flame resistance: Bs3-d0 (DIN EN 13501-1)

# Stop Ice Plus

Constant power anti-freeze kit complete with thermostat, connection plug and insulation tape.

Stop Ice Plus is an innovative kit which combines the flexibility and reliability of the constant power Stop Ice heating cable with the practicality of the LINUS insulation tape. The installer can find everything necessary for tracking inside this kit:

- Stop Ice 12 W/m constant power cable, complete with connection plug and thermostat
- 3 mm LINUS insulation tape, for application on already tracked piping with a cable with 50% overlap

As an example, with a 10 m long LINUS tape, about 2.2 m of ¾", traced with the Stop Ice cable, can be insulated.

Product	Power (W/kit)	Cable length (m)
Stop Ice Plus 2	24	2
Stop Ice Plus 5	60	5

HEATING CABLE  
 Built-in THERMOSTAT  
 Built-in PLUG



TAPE INSULATION  
 to maintain  
 temperature



CABLE  
 Specific power: 12 W/m  
 Power supply: 230 V- 50Hz  
 Cold cable: 3 x 0,75 mm<sup>2</sup> - L = 1,5 m  
 Temperature control: integrated bimetallic thermostat  
 ON / OFF: +3°C / +10°C

INSULATION TAPE  
 Temperature range: -50 / +105°C  
 Coefficient of thermal conductivity (λ): 0,039 W/mK a 50°C  
 Dimensions: 50 mm x 3 mm x L10 m





# MCA

**Self-regulating** cable for anti-freeze use or for maintaining temperatures for general use.

For anti-freeze use on pipes or tanks or for maintaining process temperatures under 65°C, even in hazardous areas. Maintenance-free, reliable, easy to install. Suitable even in the presence of mild inorganic solutions.

Product	Power voltage (V)	Minimum installation temperature (°C)	Power at 10°C (W/m)	TEMPERATURE MAX	
				Continuous cable powered (°C)	Intermittent cable not powered ≤1000 h cum. (°C)
MCA3	220-240	-30	10	65	85
MCA5	220-240	-30	15	65	85
MCA8	220-240	-30	25	65	85
MCA5-SMALL	220-240	-30	15	65	85

### How to Choose MCA Cable for Antifreeze Protection

The table gives the cable quantity for tube length unit (1st number) and the MCA cable code number (2nd number) versus tube diameter, thermal insulation thickness (for rockwool) and min outer temperature.

For uses other than anti-freeze, request design from Raytech technical direction.

### Anti-freeze for piping

Pipe Ø		Thermal insulation thickness									
		10		20		30		40		50	
		Outer temperature (°C)									
inch	mm	-10	-20	-10	-20	-10	-20	-10	-20	-10	-20
1/2"	15	1-3	1-3	1-3	1-3	1-3	1-3	1-3	1-3	1-3	1-3
3/4"	20	1-3	1-3	1-3	1-3	1-3	1-3	1-3	1-3	1-3	1-3
1"	25	1-3	1-8	1-3	1-3	1-3	1-3	1-3	1-3	1-3	1-3
1¼"	32	1-3	1-8	1-3	1-3	1-3	1-3	1-3	1-3	1-3	1-3
1½"	40	1-3	1-8	1-3	1-3	1-3	1-3	1-3	1-3	1-3	1-3
2"	50	1-8	1-8	1-3	1-8	1-3	1-3	1-3	1-3	1-3	1-3
2½"	65	1-8	1-8	1-3	1-8	1-3	1-3	1-3	1-3	1-3	1-3
3"	80	1-8	2-8	1-3	1-8	1-3	1-5	1-3	1-3	1-3	1-3
4"	100	1-8	2-8	1-5	1-8	1-3	1-5	1-3	1-5	1-3	1-3
6"	150	2-8	2-8	1-8	2-8	1-8	1-8	1-3	1-8	1-3	1-8
8"	200	2-8	-	1-8	2-8	1-8	1-8	1-8	1-8	1-3	1-8
10"	250	2-8	-	2-8	-	1-8	2-8	1-8	1-8	1-8	1-8

### ELECTRICAL SIZING

Starting temperature		Maximum length of the circuits in the heating cable (m)					
		MCA3			MCA5		
		+10°C	-10°C	-20°C	+10°C	-10°C	-20°C
Switchgear protection (A), with C curve and 30mA* differential protection	10 A	-	-	-	103	71	62
	16 A	177	144	125	160	114	99
	20 A	-	149	139	-	133	124
	25 A	-	-	-	-	-	-

Starting temperature		MCA8			MCA5-SMALL		
		+10°C	-10°C	-20°C	+10°C	-15°C	-25°C
Switchgear protection (A), with C curve and 30mA* differential protection	10 A	64	47	37	104	69	59
	16 A	103	75	60	139	89	78
	20 A	126	94	75	-	-	-
	25 A	-	107	94	-	-	-

\* Suggested where protection of people is requested; installations with no personnel admittance can be performed with 100 to 300 mA.



# MCA Compact

Compact size **self-regulating** cables for use as anti-freeze or to maintain temperature.

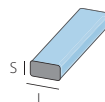

Product	Power voltage (V)	Minimum installation temperature (°C)	Power at 10°C (W/m)	TEMPERATURE MAX		L cable (mm)	S cable (mm)
				Continuous cable powered (°C)	Intermittent cable not powered ≤1000 h cum. (°C)		
MCA2-COMPACT	230	-30	10	65	65	7,7	5,3
MCA6-COMPACT	230	-30	18	65	65	7,7	5,3

ELECTRICAL SIZING

Maximum length of the circuits in the heating cable (m)

Starting temperature		MCA2-COMPACT			MCA6-COMPACT		
		+10°C	0°C	-20°C	+10°C	0°C	-20°C
Switchgear protection (A), with C curve and 30mA* differential protection	10 A	100	95	77	60	58	41

\* Suggested where protection of people is requested; installations with no personnel admittance can be performed with 100 to 300 mA.



## MCA and MCA2-COMPACT connection accessories

Connection kit integrated with the terminal box	Termination Kit	Joint Kit	Branch Kit
MCA Universal IP68	MCA Universal IP68	MCA Universal IP68	MCA-Y
Thermal insulation pass-through kit	Cable gland	Warning label	
MCA-AL	MCA-PRESS	MCA-EA	
Fixing tape glass	Fixing tape Aluminum 25mm	Fixing tape Aluminum 75mm	
MCA-FV	MCA-ALL25	MCA-ALL75	



MCA Universal IP68



See accessory specifications page 209.



## Ice Killer

Cut and install **self-regulating** cable kit, complete with connection side and termination kit.

The Ice Killer kit is composed of a 30 m self-regulating cable coil, complete with connection side and termination accessories. The cable can be cut to the desired length, installed on the pipe or tank, connected to the mains and terminated at the opposite end.

The economic and compact Ice Killer kit is sold in an attractive, easy to carry, easy to handle on-site package, is small in size, very flexible and can be easily adapted to bends in piping.

The Ice Killer cable is laid linearly or wound in piping, depending on the specific necessary power. It is then fastened to the same by means of inextensible tape (Raytech MCA-FV or MCA-ALL75 type tapes), terminated with accessories contained in the kit and then clad with the insulation. Operating temperature is reached very quickly and is maintained almost constant even with room temperature variations.



- Supply voltage: 230 V
- Min installation temperature: -30°C
- Cable dimensions: 7,7 x 5,3 mm
- Max temperature with powered cable: 65°C
- Max exposure temperature with non-powered cable: 65°C



Product	Specific power a 10°C (W/m)	Kit composition
Ice Killer 2	10	30 m cable Connection accessory Termination accessory
Ice Killer 6	18	30 m cable Connection accessory Termination accessory

ELECTRICAL SIZING	Maximum circuit length (m)			
	Ice Killer 2		Ice Killer 6	
Starting temperature	0°C	-20°C	0°C	-20°C
10 A electrical protection, characteristic C switch with differential 30 mA protection	95	77	58	41





### ANTI-FREEZE FOR RAMPS

Constant power

## Tracking Systems

### ANTI-FREEZE FOR GUTTERS AND PIPING

# Easy Cable

Constant, versatile power heating cable complete with termination accessory and power cable.

Especially suitable for solving anti-freeze problems: snow or ice accumulation on access ramps, walkways and stairs, or for frost protection of pipes or tanks, under adequate insulation. 3 standard lengths are available, with a specific power of 25 W/m, covering all possible tracking types. Complete with termination accessory and power cable, Easy cable is a shielded heating cable under a protective sheath with two conductors, with extremely simple and quick installation and connection. Please note that the cable should never be cut, spliced or overlapped.



**Power supply:** 230 V, 50/60 Hz  
**Cable dimensions:** ~ 5x7 mm  
**Min. installation temperature:** +5°C  
**Max. working temperature:** +80°C  
**Heating cable type:**  
 2 conductors, screened cable  
**Specific power:** 25 W/m  
**Insulation:** XLPE  
**External sheath:** PVC  
**Marking:** CE

**FOR RAMPS** - installation depth about 50 mm with respect to the surface.

Product	Specific power (W/m)	Length (m)	Rated power (W)	Maximum length for each individual wheel passage	
				(A) 4 passages	(B) 5 passages
Easy Cable 26/25	25	26,5	655	6 m	5 m
Easy Cable 44/25	25	44	1120	10,5 m	8,5 m
Easy Cable 92/25	25	92	2270	22,5 m	18 m

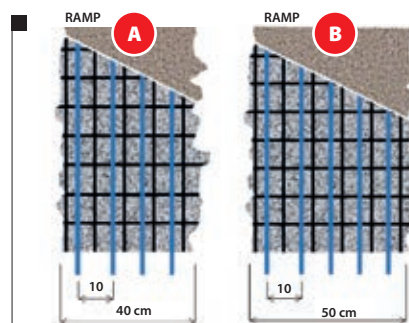

**FOR PIPES** - anti-freeze tracking for piping, longitudinal linear installation 1 m cable/m pipe.

Product	Specific power (W/m)	Total rated power (W)	Anti-freeze for pipes up to 2 1/2" (Dn 65 mm), for minimum temperatures up to -15°C, with rock wool thickness	Anti-freeze for pipes from 3" (Dn 80) up to 6" (Dn 200 mm), for minimum temperatures up to -15°C, with rock wool thickness
Easy Cable 26/25	25	655	10 mm	20 mm
Easy Cable 44/25	25	1120	10 mm	20 mm
Easy Cable 92/25	25	2270	10 mm	20 mm

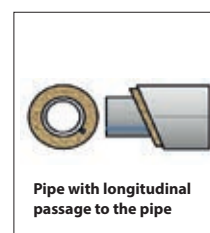

## Control unit for Easy Cable for ramps.

The C 2000 control unit, to be completed with the C2000-SR temperature, snow and humidity sensor (sensor to be placed flush with the ramp and to be ordered separately from the control unit), activating the power contactor, gives consent to start the system only when low temperature and snow or ice are present simultaneously, optimising energy consumption.

Control unit	Temperature, snow and humidity sensor
C2000	C2000-SR





## Tracking systems

# ANTI-FREEZE FOR RAMPS, STEPS AND WALKWAYS

To keep garage access ramps, parking areas, outdoor stands and walkways free of snow and ice.

Available in both the **constant power** and in the **self-regulating** versions.



**Mat specific power:** 300 W/m<sup>2</sup>  
**Power supply:** 230 V ~ 50/60 Hz  
**Mat thickness:** 7,5 mm  
**Min. installation temperature:** + 5°C  
**Max. working temperature:** + 80°C  
**Cold cable (supply):**  
 length 4 meters - 3 x 1,5 mm<sup>2</sup> or 3x2,5 mm<sup>2</sup>  
**Heating cable type:**  
 2 conductors, screened cable  
**Heating cable dimensions:** ~ 5 x 7 mm  
**Heating cable power:** 25 W/m  
**Insulation:** XLPE  
**External sheath:** PVC  
**Marking:** CE

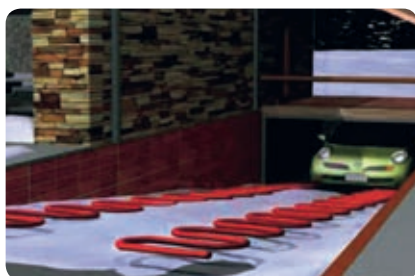

## Easy Ramp

**Constant wattage** heating mat.

Raytech Easy Ramp consists of a constant wattage heating cable assembled with tape to form a heating mat, which is easily and quickly spread on the surfaces to be protected. Easy Ramp is ideal for solving the problems caused by ice formation and the accumulation of snow on the access ramps to garages, pathways, outdoor parking areas, footpaths, etc. It can be installed in concrete, asphalt, and interlocking bricks or under porphyry paving or other paving materials blocked with cement and sand. The standard width of Easy Ramp pads is 60 cm; a sufficient width to free the track of vehicle wheels from ice and snow or to create an extremely safe pedestrian pathway.

The power density developed by Easy Ramp is 300 W/m<sup>2</sup>. The mat is available in various lengths which are easily adaptable to the size of the area to track and where the size of the mat is larger than that of the ramp, the excess part of mat can be easily folded 90 degrees. The mat is supplied completely finished and ready for installation, complete with 4 meters of cold cable (3x1.5 mm<sup>2</sup> or 3x2.5 mm<sup>2</sup>) for connection to the power supply. The constant wattage heating cable, which constitutes the mat, is a 2 conductor heating cable, which is shielded; this allows one end only to be powered, making installation even faster and easier.

Product	Power (W)	Specific power (W/m <sup>2</sup> )	Width (m)	Length (m)
Easy Ramp 4/300	670	300	0,6	4
Easy Ramp 7/300	1140	300	0,6	7
Easy Ramp 13/300	2560	300	0,6	13
Easy Ramp 21/300	3730	300	0,6	21





# MCA Ramp

**Self-regulating** heating cable.

The cable is used, buried in concrete, to prevent the accumulation of ice and its formation on access ramps, stairs, sidewalks, parking lots, walkways, etc. Suitable for ramps covered in concrete, interlocking brick or asphalt, both for light and heavy traffic. The cable can be installed on ramps under construction, securing the electrowelded mesh prior to pouring of the concrete, or else on already completed ramps by cutting the concrete surfaces to then fill with plastic cement after installation of the cable, or simply by laying the cable on the surface of the ramp and throwing another layer of cement.

### Cable roofing cement or interlocking, asphalt, gneiss, and any other material

Product	Power at 0°C in concrete (W/m)	Max working temperature (°C)	Cable length	
			Switgear*	Maximum length (m)
MCA 20-I-GF	90	120	40 A	64
MCA 10**	50	65	40 A	90

\* Differential protection 30 mA

\*\*For ramps, stairs etc. with ambient temperature not lower than -15°C; for lower temperatures use only MCA 20-I-GF cable. For draining trenches tracing MCA8 cable shall be used. For other information contact Raytech.

Note: to trace drain outlets, use the MCA8 cable installed on the bottom of the outlets under the grate.

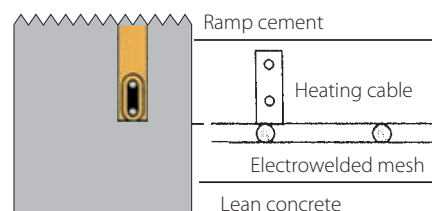

## MCA Ramp connection accessories

Connection kit integrated with the terminal box	Termination Kit	Joint Kit	Cable gland
MCA Universal IP68	MCA Universal IP68	MCA Universal IP68	MCA-PRESS

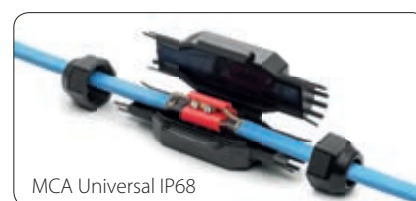

## Control unit for Easy Ramp and MCA Ramp

The C 2000 control unit, to be completed with the C2000-SR temperature, snow and humidity sensor (sensor to be placed flush with the ramp and to be ordered separately from the control unit), activating the power contactor, gives consent to start the system only when low temperature and snow or ice are present simultaneously, optimising energy consumption.

Control unit	Temperature, snow and humidity sensor
C2000	C2000-SR



For other accessories see page 209.



## Tracing systems

# ANTI-FREEZE FOR GUTTERS

Contact and self-regulating power cables to prevent the formation of ice and snow accumulation in gutters, downspouts and roof pitches.

## Easy Frost

**Constant power heating** cable for roofs, gutters and downpipes.

Raytech Easy Frost is a 20 W/m constant power cable especially designed for roofs, gutters and downpipe protection from damage due to snow accumulation and ice formation. Easy Frost is supplied terminated and ready for installation, with 4 metres of cold cable (3 x 1,0 mm<sup>2</sup> o 3 x 1,5 mm<sup>2</sup>) for supply connection.

**Power:** 20 W/m  
**Power supply:** 230 V ~ 50/60 Hz  
**Heating cable dimensions:** ~ 5 x 7 mm  
**Min. installation temperature:** + 5°C  
**Max. working temperature:** + 80°C  
**Cold cable (power supply):**  
 length 4 meters - 3 x 1,0 mm<sup>2</sup>  
 or 3 x 1,5 mm<sup>2</sup>  
**Heating cable type:**  
 2 conductors, screened cable  
**Insulation:** XLPE  
**External sheath:** PVC  
**Min. bending radius:** 3,5 D  
**Marking:** CE

Product	Power (W)	Specific power (W/m)	Resistance (Ω)	Length (m)
Easy Frost 50/20	1000	20	52,9	50
Easy Frost 102/20	2040	20	29,9	102



Note: control unit C2000 works only when connected to both the C2000-SUG and C2000-STG sensors.

### Control unit for MCA 8 and Easy Frost

ON/OFF type control unit C 2000 to activate the power switch, to be completed with C 2000-STG temperature detection sensor and C 2000-SUG wet surfaces sensor: activates the system only when low temperature and water, ice or snow is present. (C 2000-STG and C 2000-SUG sensors are to be ordered and purchased separately from the control unit).

Control unit	Temperature sensor	Ice and snow sensor
C2000	C2000-STG	C2000-SUG

For other accessories see page 209.



# MCA 8

**Self-regulating** cable for tracing roofs, gutters and/or downpipes.

**Prevents**

The formation of ice inside gutters and downspouts, snow accumulation and ice on roofs, the development of infiltrations along façades, the development of ice sticks along gutters and roof ends.

**Avoiding**

Gutter breaking under the weight of snow, bursting and fracturing of drainpipes due to water freezing, damaged caused by a lack of draining caused by drain clogging, damage to persons or property caused by falling ice sticks, damage to persons or property caused by possible snow slides off rooves from roof edges.

Product	In air 0°C Power (W/m)	In chilly water Power (W/m)	Maximum cable length with starting temperature of -10°C through a switchgear (*) of		
			16 A	20 A	30 A
MCA8	24	40	40 m	50 m	90 m

\*Switchgear with "C" characteristic, having a differential protection of 30 mA

Note: the gutter cable is suspended along the down side of the drain pipes with accessory MCA-SUP. The cable is self-supporting up to 25 m vertical sections; in addition, an extra MCA-SUP accessory is provided for every 25 m, to which the cable is secured.

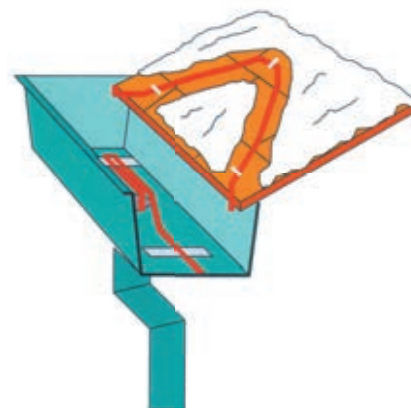

The image shows gutter installation, the input of cable in a downpipe and tracking of a roof pitch.

## MCA 8 connection accessories

Connection kit integrated with the terminal box	Termination Kit	Joint Kit
MCA Universal IP68	MCA Universal IP68	MCA Universal IP68
Branch Kit	Support device	
MCA Universal	MCA-SUP	

For other accessories see page 209.



MCA Universal IP68







# INDUSTRIAL USE

Anti-freeze maintenance  
and heating  
**up to 65°C continuous**  
**85°C intermittent**

**ATEX**



MCA3

MCA5

MCA7-I-PF

MCA8

MCA10

MCA13-I

Anti-freeze maintenance  
and heating  
**up to 120°C continuous**  
**120°C intermittent**



MCA3-I-GF

MCA5-I-GF

MCA8-I-GF

MCA10-I-GF

MCA20-I-GF

Anti-freeze maintenance,  
heating and washing  
**up to 120°C continuous**  
**190°C intermittent**

**ATEX**



MCA3-I-FF

MCA5-I-FF

MCA7-I-FF

MCA8-I-FF

MCA10-I-FF

MCA15-I-FF

MCA20-I-FF



**SELF-REGULATING**

Up to 65°C continuous - 85°C intermittent

**ATEX**

**MCA**

**Self-regulating** heating cables for anti-freeze or temperature maintenance use with exposure to **mild inorganic solutions**.

Suitable for anti-freeze and process temperature maintenance use **up to 65°C** on piping and tanks. Cannot be used when washing with steam or continuous exposure to strong corrosive and organic acids.

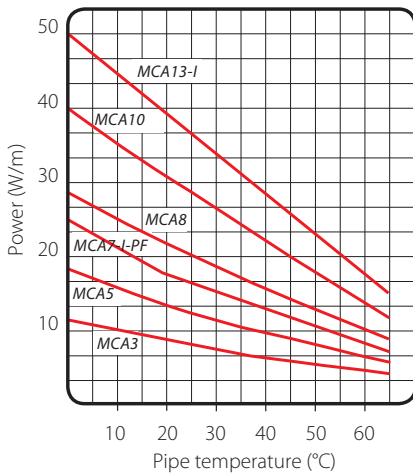

**CONSTITUTION OF THE CABLE**

- Copper conductors
- Self regulating conductive core
- Modified polyolefine insulation
- Copper screen
- Modified polyolefine or fluoropolymer (I-PF) outer sheath

**Cables certified for classified zones**

Ex II 2G Ex e IIC Gb  
Ex II 2D Ex tb IIIC Db  
In accordance:  
EN 60079-0 :2009  
EN 60079-31 :2009  
EN 60079-30-1 :2009

**Type of surface to be tracked:**

Steel - Painted - Stainless Steel - Plastic.

**Chemical resistance:** Suitable for exposure to mild inorganic solutions.

Product	Power voltage (V)	Power at 10°C (W/m)	Minimum installation temperature (°C)	MAX TEMPERATURE		Bending radius min. (mm)	Temperature classification EN50014
				Continuous cable powered (°C)	Intermittent cable not powered ≤1000 h cum. (°C)		
MCA3*	230	10	-45	65	80	25	T6
MCA5*	230	15	-45	65	80	25	T6
MCA7-I-PF	230	20	-45	65	80	25	T6
MCA8*	230	25	-45	65	80	25	T6
MCA10*	230	30	-45	65	80	25	T6
MCA13-I	230	40	-45	65	80	25	T6

Add the abbreviation **I-PF** for external fluoropolymer sheaths

ELECTRICAL SIZING	Maximum length of the circuits in the heating cable (m)																	
	MCA3			MCA5			MCA7-I-PF			MCA8			MCA10			MCA13-I		
Starting temperature (°C)	+10°	-10°	-20°	+10°	-10°	-20°	+10°	-10°	-20°	+10°	-10°	-20°	+10°	-10°	-20°	+10°	-10°	-20°
10 A	-	-	-	103	71	62	-	-	-	64	47	37	49	38	33	-	-	-
16 A	177	144	125	160	114	99	109	79	70	103	75	60	78	61	53	57	44	40
20 A	-	149	139	-	133	124	129	99	87	126	94	75	97	76	66	71	55	50
25 A	-	-	-	-	-	-	-	111	104	-	107	94	112	95	83	89	69	62

\* Suggested where protection of people is requested; installations with no personnel admittance can be performed with 100 to 300 mA.

**MCA connection accessories**

Connection kit integrated with the terminal box	Termination Kit	Joint Kit	Branch Kit	Thermal insulation pass-through kit
MCA Universal IP68	MCA Universal IP68	MCA Universal IP68	MCA-Y	MCA-AL
Cable gland	Warning label	Fixing tape glass	Fixing tape Aluminum 25mm	Fixing tape Aluminum 75mm
MCA-PRESS	MCA-EA	MCA-FV	MCA-ALL25	MCA-ALL75

For other accessories see page 209.



# MCA-I-GF

**Self-regulating** heating cables for anti-freeze or temperature maintenance use with exposure to **corrosives and acids**.

Suitable for maintaining process temperatures **up to 120°C** on piping and tanks, even in the presence of acids and corrosives, or for anti-freeze use where acids and corrosives are present, in safe areas. Not suitable for use in the presence of steam washing.

#### CONSTITUTION OF THE CABLE

Copper conductors

Self regulating conductive core

Fluoropolymer insulation

Copper screen

Modified polyolefine outer sheath

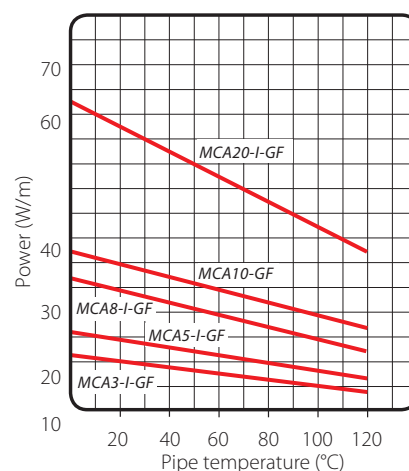

#### Type of surface to be tracked:

Steel - Painted - Stainless Steel.

**Chemical resistance:** Suitable for exposure to corrosive and organic acids.

Product	Power voltage (V)	Power at 10°C (W/m)	Minimum installation temperature (°C)	MAX TEMPERATURE		Bending radius min. (mm)	Temperature classification EN50014
				Continuous cable powered (°C)	Intermittent cable not powered ≤1000 h cum. (°C)		
MCA3-I-GF	230	10	-30	120	120	25	T3
MCA5-I-GF	230	15	-30	120	120	25	T3
MCA8-I-GF	230	25	-30	120	120	25	T3
MCA10-I-GF	230	30	-30	120	120	25	T3
MCA20-I-GF	230	60	-30	120	120	25	T3

#### ELECTRICAL SIZING

Maximum length of the circuits in the heating cable (m)

Starting temperature		MCA3-I-GF			MCA5-I-GF			MCA8-I-GF			MCA10-I-GF			MCA20-I-GF		
		+10°C	-15°C	-25°C	+10°C	-15°C	-25°C	+10°C	-15°C	-25°C	+10°C	-15°C	-25°C	+10°C	-15°C	-25°C
Switchgear protection (A), with C curve and 30mA* differential protection	16 A	200	180	175	165	130	117	120	97	88	85	73	69	50	41	38
	20 A	235	235	235	189	162	152	140	125	120	114	98	92	64	55	52
	30 A	-	-	-	-	-	189	-	-	140	-	-	114	-	-	64

\*Suggested where protection of people is requested; installations with no personnel admittance can be performed with 100 to 300 mA.

## Connection accessories for MCA-I-GF

Connection kit integrated with the terminal box	Termination Kit	Joint Kit	Branch Kit	Thermal insulation pass-through kit
MCA Universal IP68	MCA Universal IP68	MCA Universal IP68	MCA-Y	MCA-AL
Cable gland	Warning label	Fixing tape glass	Fixing tape Aluminum 25mm	Fixing tape Aluminum 75mm
MCA-PRESS	MCA-EA	MCA-FV	MCA-ALL25	MCA-ALL75

For other accessories see page 209.



**ATEX**

# MCA-I-FF

**Self-regulating** heating cables for anti-freeze or temperature maintenance use with exposure to **corrosives and acids and high temperatures.**

Suitable for maintaining process temperatures **up to 120°C** on piping and tanks, even in the presence of acids and corrosives, or for anti-freeze use even in the presence of acids and corrosives and where high temperature thermal treatment is foreseen, like steam washing, **up to 190°C.**

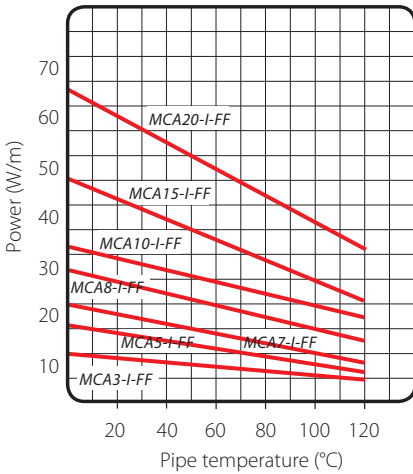

**CONSTITUTION OF THE CABLE**

- Copper conductors
- Self regulating conductive core
- Fluoropolymer insulation
- Copper screen
- Fluoropolymer outer sheath

**Cables certified for classified zones**

Ex II 2G Ex e IIC Gb  
Ex II 2D Ex tb IIIC Db  
In accordance:  
EN 60079-0:2009  
EN 60079-31:2009  
EN 60079-30-1:2007

**Type of surface to be tracked:**  
Steel - Painted - Stainless Steel  
- Plastic.

**Chemical resistance:** Suitable for exposure to corrosive and organic acids.

Product	Power voltage (V)	Power at 10°C (W/m)	Minimum installation temperature (°C)	TEMPERATURE MAX		Bending radius min. (mm)	Temperature classification EN50014
				Continuous cable powered (°C)	Intermittente a cavo non alimentato ≤1000 h cum. (°C)		
MCA3-I-FF	230	10	-30	120	190	25	T3
MCA5-I-FF	230	15	-30	120	190	25	T3
MCA7-I-FF	230	20	-30	120	190	25	T3
MCA8-I-FF	230	25	-30	120	190	25	T3
MCA10-I-FF	230	30	-30	120	190	25	T3
MCA15-I-FF	230	45	-30	120	190	25	T3
MCA20-I-FF	230	60	-30	120	210	25	T3

**ELECTRICAL SIZING**

Maximum length of the circuits in the heating cable (m)

Starting temperature (°C)	Switchgear protection (A), with C curve and 30mA* differential protection	MCA3-I-FF			MCA5-I-FF			MCA7-I-FF			MCA8-I-FF			MCA10-I-FF			MCA15-I-FF			MCA20-I-FF		
		+10°	-15°	-25°	+10°	-15°	-25°	+10°	-15°	-25°	+10°	-15°	-25°	+10°	-15°	-25°	+10°	-15°	-25°	+10°	-15°	-25°
+10°	16 A	200	180	175	165	130	117	122	107	102	120	97	88	85	73	69	55	48	36	50	41	38
	20 A	235	235	235	189	162	152	136	127	124	140	125	120	114	98	92	68	60	57	64	55	52
	30 A	-	-	-	-	-	189	-	-	-	-	-	140	-	-	114	91	83	82	-	-	64

\* Suggested where protection of people is requested; installations with no personnel admittance can be performed with 100 to 300 mA.

**Connection accessories for MCA-I-FF**

Connection kit integrated with the terminal box	Termination Kit	Joint Kit	Branch Kit	Thermal insulation pass-through kit
MCA Universal IP68	MCA Universal IP68	MCA Universal IP68	MCA-Y	MCA-AL
Cable gland	Warning label	Fixing tape glass	Fixing tape Aluminum 25mm	Fixing tape Aluminum 75mm
MCA-PRESS	MCA-EA	MCA-FV	MCA-ALL25	MCA-ALL75

For other accessories see page 209.

# Accessories



## MCA Universal IP68 and MCA-Y

Universal accessory for heating cable.

A revolutionary accessory is now available that is suitable for any type of self regulating heating cable either with or without screening. Its versatility provides a reliable unique solution unavailable elsewhere in the market. It has no shelf life and no tools are required during installation (including blow torches).

- Versatile and ready to use
- No need for tools
- Without heating
- Installable at any temperature
- Can be used directly underground
- Very compact
- Re-enterable
- Non toxic and flame retardant
- The connections are automatically blocked when the joint is closed
- Screw connectors available with the kit
- Can be used underwater
- Without shelf life



Straight joint between Heating cables



Connection termination to the power cable



Pot end



Branch joint

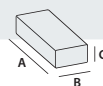

Dimension  
A x B x C (mm)

Product	Kit Composition	Dimension A x B x C (mm)
MCA Universal IP68	3 screw connectors to connect to the power cable or another heating cable	125 x 43 x 35
MCA-Y	3 screw connectors for branch connections between heating cables	160 x 75 x 37

**Electrical:**

EN 50393 and CEI 20-33  
(Note: with testing under water head and water between the cable cores), in Class 2

**Flame non propagation:**

IEC 60332-1 and HD 405-1 (as applicable)

## MCA BOX

Pre-filled gel connection boxes for heating cables.

Boxes for single or multiple connections either between heating cables or heating and power cables. Ready to use, pre-filled with gel, complete with terminal block and screws, they allow the connection between heating cables and between heating cables and power cables, ensuring IP68 and IP69K degree of protection. They are suitable for power cables from 8 to 18 mm diameter and/or for power supplies with insulated wires in conduits of 16, 20, 25 and 32 mm diameter. MCA BOX is essential in damp environments and in areas subject to condensation or flooding. Available as either 3 or 4 entry in order to satisfy any installation requirement.

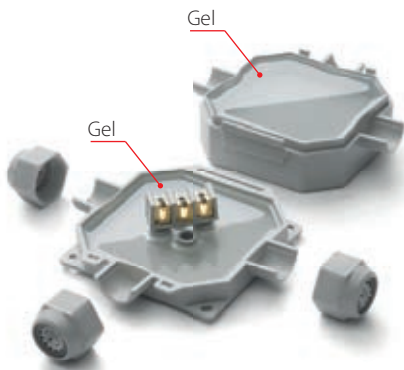

MCA BOX 3

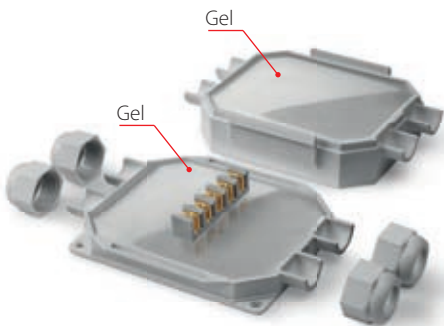
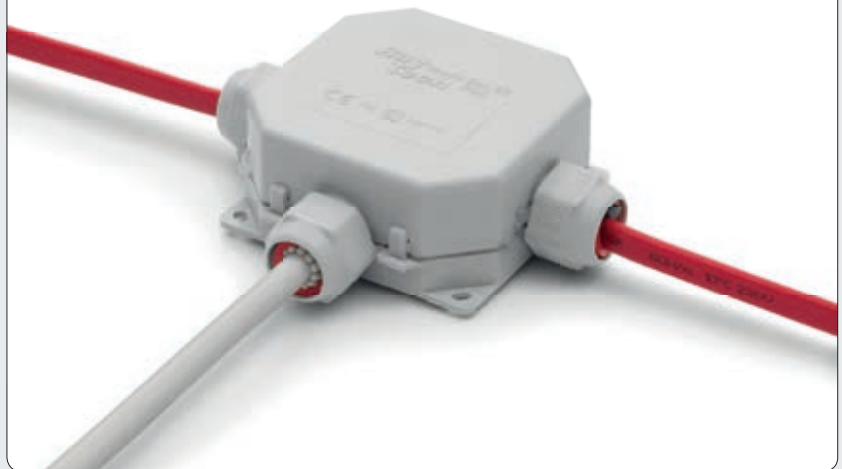

MCA BOX 4

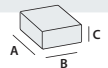

Product	Kit composition	A x B x C (mm)
MCA BOX 3	Gel-prefilled box Terminal block 3 x 6 mm <sup>2</sup> + adaptors	90 x 90 x 45
MCA BOX 4	Gel-prefilled box Terminal block 4 x 6 mm <sup>2</sup> + adaptors	120 x 100 x 45

## MCA-PC, MCA-PC-Compact

Connection kit.

Supply side termination allowing connections to a terminal box. Made of cold-shrink components and also a dedicated cable gland. One for each cable.



## MCA-PM, MCA-PM-Compact

Termination kit.

For insulating and matching the cable ends. Made from cold-shrink components. One kit for each termination.



## MCA-AL

Thermal insulation pass-through.

It allows the cable to pass through the metallic covering of the thermal insulation, avoiding abrasions and the moisture or water entry under the covering. It contains cable gland and fixing plate. One kit for each cable.



## MCA-GL

Joint kit.

To joint cable ends or to repair damaged cables. It contains all the components required, including connectors. One kit for each cable.

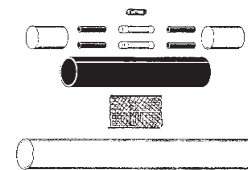

## MCA-PRESS

Cable gland.

To allow the cable to enter in boxes, to pass through walls etc. One kit per cable.







### MCA-SUP

Support device for gutters and down pipes.

It supports and fixes the cable in gutters and downpipes. In large gutters, requiring 2 cables laid longitudinally, it maintains the cable at the right distance.

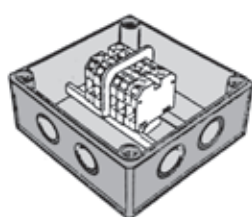

### MCA-SG

Box.

Box with IP55 degree of protection, complete of terminals. It allows the entry of 1 or more heating cables, or to branch a cable from a main tracing, or to joint cable lengths. Cables inside the box shall be MCA-PC terminated.



### MCA-FV

Glass fiber tape.

To fix the cable to the pipe, 3 turns every 0,3 m of pipe. Self adhesive, in 50 m rolls.



### MCA-ALL75

Aluminium self adhesive tape 75 mm width.

For cable fixing, in 50 m rolls.



### GUAT 26

Connection kit for classified area.



### MCA-EA

Warning label.

To be applied for warning over traced items.

## Control Unit C2000

C 2000 Control unit for temperature and humidity.

The C2000 control unit and relative sensors are suitable for the tracing with both self-regulating cables and constant power cables. The unit allows you to power the system only when low temperatures and humid surfaces (snow - ice, etc.) are present simultaneously.

### Segnalling lamps

**ON** (green) voltage

**RELAY** (red) cable on power

**MOIST** (red) humidity presence

**TEMP** (red) the temperature is lower than the fixed

**Voltage:** 230V c.a. +/- 10% 50/60Hz

**Output:** N° 1 relays

**Switching capacity:** 16A (3600 W)

**Differential ON/OFF:** 0,4°C

**Temperature Range:** 0-10°C

**After run time:** 1-6 hours

**Protection degree:** IP20

**Dimensions:** 85 x 42 x 48,8 mm

**Weight:** 252 gr

**Room temperature:** 0/50°C



## C2000 - SR

Humidity and temperature sensor for ramps and stairs.

**Dimensions:** h 32 mm - Ø 60 mm

**Protection degree:** IP68

**Ambient temperature:** -20°C / +70°C

**Connecting cable:** 6x1,5 mm<sup>2</sup>, lenght. 10 m  
(possible increase up to 200 m)



## C2000 - SUG

Ice and snow sensor for gutters.

**Dimensions:** 105 x 30 x 10mm

**Protection degree:** IP68

**Ambient temperature:** -20°C / +70°C

**Connecting cable:** 4x1,5 mm<sup>2</sup>, lenght.10 m  
(possible increase up to 200 m)

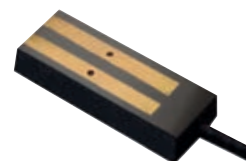

## C2000 - STG

Temperature sensor for gutters.

**Dimensions:** 86 x 45 x 35 mm

**Protection degree:** IP55

**Ambient temperature:** -20°C / 70°C

**Connecting cable:** not included







# COMFORT HOUSE

## Flooring

PRIMARY, SECONDARY OR FLOORING COMFORT HEATING SYSTEMS



**Easy Floor**  
For the intelligent tracing of tile, marble, etc. floors



**Easy Wood**  
For the intelligent tracing of wood or laminate flooring



**Raytech Intelligent Display**  
Intelligent room timed thermostat

## Mirror

SELF-ADHESIVE HEATING SHEET

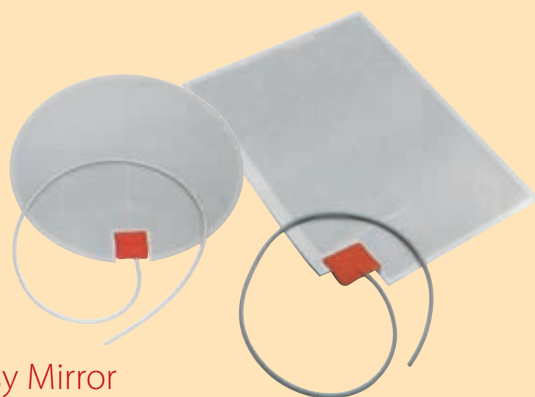

Easy Mirror

## Ceiling

CEILING HEATING PANELS

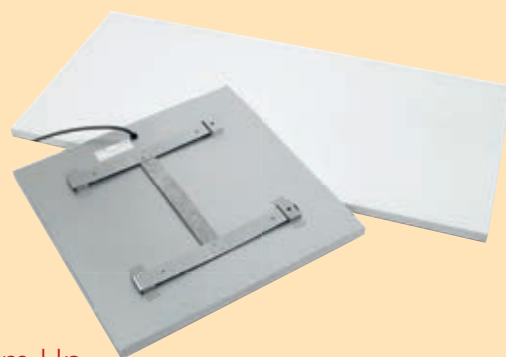

Warm Up

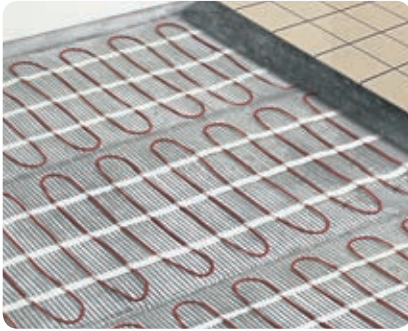

# Comfort House

Primary, secondary or flooring comfort heating systems.

Heating mats and intelligent timed thermostat: Raytech intelligent systems for primary, secondary and flooring heating comfort for homes, offices, kindergartens, schools and hospitals.

## Constant power heating mats for flooring

Combining the total reliability of the Raytech mat system with the RID microprocessor intelligent thermostat, it is possible to autonomously control all space heating parameters, as a primary means in less cold months and as a secondary means together with a more traditional system, and for comfort heating in bathrooms, kitchens, living rooms and children's bedrooms. After the first programming of the RID timed thermostat, you are free to forget about the system, which will run itself, ensuring optimal conditions.





# Easy Floor

Heating mat for the intelligent tracing of tile, marble, floors, etc.

The Easy Floor mat is laid directly on a layer of thermal insulation that coats the floor finished with concrete, and then buried in self-levelling concrete and covered with tiles. The flooring tracing mats are supplied in standard widths of 50 cm, power 150 W/m<sup>2</sup>.

Product	Width (m)	Length (m)	Power (W)
Easy Floor 2	0,5	2	150
Easy Floor 3	0,5	3	225
Easy Floor 4	0,5	4	300
Easy Floor 2-ST	0,5	2	150
Easy Floor 3-ST	0,5	3	225
Easy Floor 4-ST	0,5	4	300

Other sizes available upon request



**The kit is composed of:**

- Heating mat complete with cold tail
- RID microprocessor intelligent room timed thermostat complete with sensor
- Corrugated pipe for positioning

Note: -ST type kits are supplied without a RID room timed thermostat





**The kit is composed of:**

Heating mat complete with connection wires and connectors, tapes and grippers for connection.

RID microprocessor intelligent room timed thermostat complete with sensor.

Corrugated pipe for sensor positioning

Note: provide for thermal insulation of at least 6 mm in thickness (e.g. sheet of polystyrene) under the heating sheet and a barrier against humidity (polythene sheet at least 0.1 mm) above.

Contact Raytech for any clarifications.

# Easy Wood

Heating mat for the intelligent tracing of wood or laminate floors.

Easy Wood is a very thin film (only 0.3 mm) controlled by a digital intelligent timed thermostat with RID microprocessor supplied with the kit. It is advisable not to exceed a temperature of 28°C. Suitable for secondary or comfort heating.

Product	Width (m)	Length (m)	Power (W)
Easy Wood 8	0,6	8,4	80
Easy Wood 16	0,6	16,8	80

Other sizes available upon request.

### Installation sequence

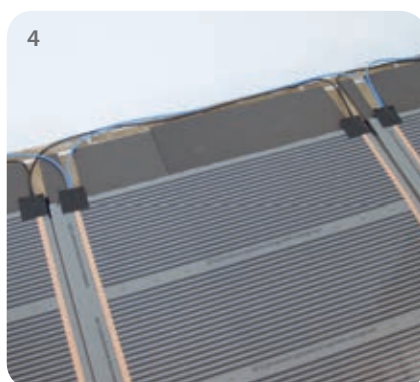
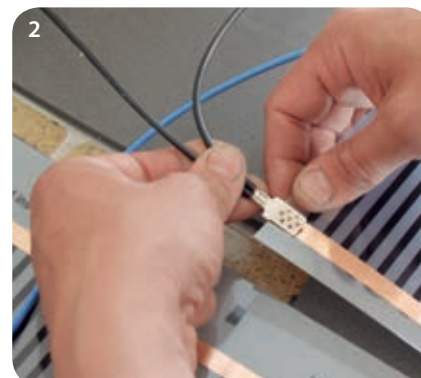



## Raytech Intelligent Display

Intelligent room timed thermostat.

The RID (Raytech Intelligent Display) microprocessor room timed thermostat is simple to use, thanks to its step-by-step programming guide. The easy to read display supplies a complete explanation of set parameters after 10 seconds.

It includes a wood floor function, which limits the temperature to 28°C for wood flooring.

The RID autonomously controls all room functions, with no need for extra operations. Weekly programming makes it possible to take into account the set temperature to be maintained, the type and thickness of the flooring, temperature limits not to be exceeded, modes for increasing temperature, etc.

This device is equipped with an anti-freeze function when the house is not inhabited, a block for untimely interventions (for example children) and communicates any operating failures to the appropriate alarms.



Sensor	Included with the kit
Temperature range	+5 / +50°C
Temperature limit	+5 / +55°C
Start Up Programme	Automatic, self learning
Manual	0,1-10°C
Room temperature	0 / +40°C
Differential On/Off	Standard 0,4°C Adjustable 0,1-1°C
Power supply	230 V / 50-60 Hz
Self-consumption	5 W
Max output current	16 A (3400 W/220 V)

Product	Dimensions (mm)
RID room thermostat	85 x 85 x 45



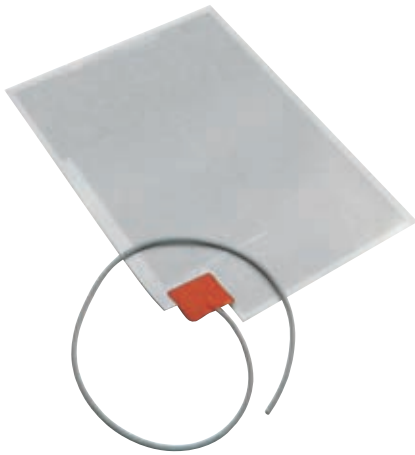

# Easy Mirror

Self-adhesive heating sheet.

No more fogged mirrors after a shower or bath! Easy Mirror, the self-adhering heating sheet to be applied on the back of the mirror and connected to the mains, eliminates this problem! Powered 230V, double insulated in accordance with safety regulations. Brings the surface of the mirror to 30°C in about 3-5 minutes, removing the film of moisture. Easy Mirror sheets are packaged with a sheet of laminated aluminium on polyester, with double insulation made with 4 more sheets of vulcanised polyester, completely sealed against water.

- Ideal for bathrooms, saunas, kitchens, private homes, Hotels, gyms and sports facilities

Product	Sheet dimensions (cm)	Power (W)
Easy Mirror 35	Ø 35	50
Easy Mirror 36/50	36 x 50	50

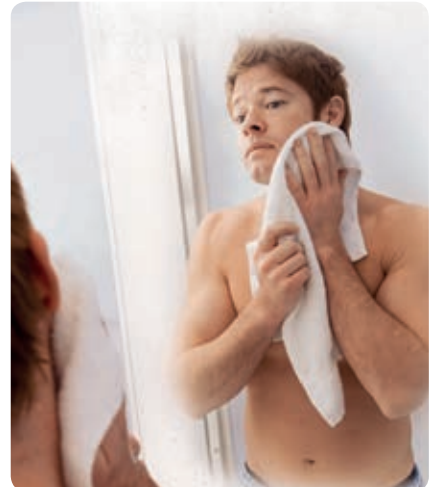

### Installation Sequence

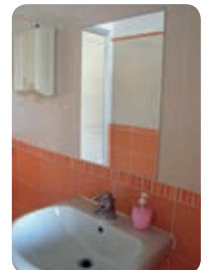
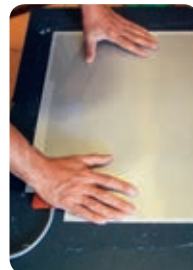
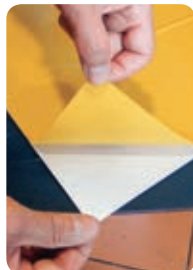



# warm up

Ceiling heating panels

Heat where you want it, when you want it



The ideal solution for all low thermal comfort environments





# Warm Up

Ceiling heating panels.

WARM-UP ceiling heating panels by Raytech can be installed invisibly and built into the ceiling of any home, office, showroom, workshop, greenhouse, camper vans etc., maximising space and freeing up wall space. Their positioning does not require any invasive procedures on the walls of the room, and their electrical connection is extremely simple. They can be installed, possibly placing them at the points where maximum thermal efficiency is required, with any mounting system: hung with chains, flush mounted, or recessed in false ceilings, always easily and quickly. The type of heating, based on infrared radiation, which makes it similar to solar radiation, is safe and unharmed, quick, efficient and extremely comfortable.

## Why choose the Warm-Up System?

- It is installed without requiring any invasive procedures to be carried out on the structures of the house.
- It is easily uninstalled for re-use in another context.
- Its radiated heat is safe, with no air movement, and does not dirty the walls and room.
- It is used for primary heating and for secondary heating as an integrative system, and optimises and reduces heating costs thanks to the RID-WL thermostat.

An ideally integrated invisible system that can also be decorative!



VERANDAS



PREFABRICATED BUILDINGS

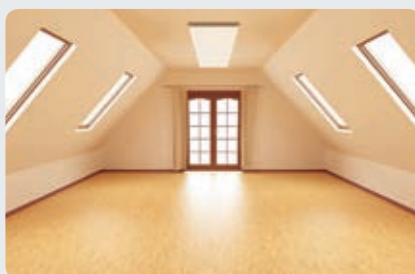

EXHIBITION SPACES



GAZEBOS

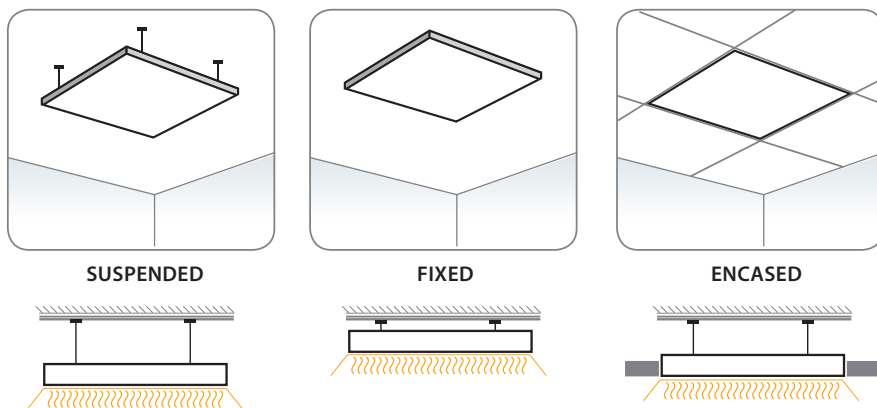

Controlled by a timed thermostat or a power regulator, they reduce consumption to a minimum

**Class 2**  
degree of protection IP44

**Power required for comfort heating:**  
about 60W/m<sup>2</sup>  
(one Warm Up 1 panel every 5m<sup>2</sup>)

**For primary heating with well-insulated walls:**  
about 120W/m<sup>2</sup>

### What Are the Benefits to the System compared to others?

- Heating is immediate, in just a few minutes.
- It leaves room walls free because it is installed on the ceiling, flush mounted or recessed in false ceilings.
- It does not pollute, as it does not use gas or hydrocarbons.
- It optimises heating and reduces costs.
- Unlike other types of heating systems, it does not require maintenance!
- It uses the energy produced by photovoltaic systems, reducing heating costs.
- It can be coloured, and is therefore easily camouflaged or used as a decorative element.



Product	Color	Power	Dimensions (mm)
Warm Up 1	White, Paintable	300 W	590 x 590 x 40
Warm Up 2		600 W	1190 x 590 x 40

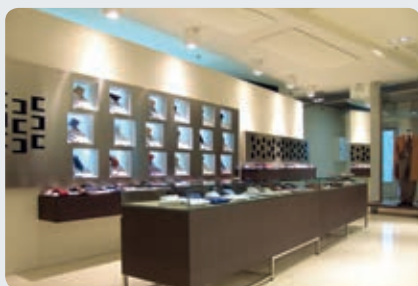

STORES



OFFICES



WAREHOUSES - GARAGES



HOMES



## Warm Up accessories

### RID-WL

Digital wireless timed thermostat.

Raytech has established the innovative WIRELESS RID-WL TIMED ROOM THERMOSTAT for maximum efficiency and speed and ease of installation. This system combines well-known reliability and control of environmental parameters of the system RID with a wireless connection.

The RID-WL, which operates in radio frequency, allows non-invasive installation in any environment, both for new installations and those related to renovations, or to reinforce an existing primary system.

The RID-WL is coupled with its own receiver, tuned to the frequency of its own thermostat (exclusive signal), which is able to control an ampacity of 8 A.

RID-WL, since it is not wired, it can be moved within the range of use and positioned where controlling the parameters is important.

It is equipped with an easy to read backlit LCD screen and is programmable and provided with a built-in internal sensor, but can be connected to a separate sensor, for example on the floor.



- Temperature accuracy:** 0,1°C
- Field of operation:** from 0°C to +40°C
- Field of temperature:** from 5°C to +35°C
- Power supply:** 2 AAA 1.5 V batteries
- Degree of protection:** IP30
- Frequency:** 868 MHz
- Powered receiver:** 230 V, 50 Hz
- Relay range:** 8 A
- Range in distance:** 100 m outdoors, 30 m indoors

- Programmable in 30 minute blocks
- 9 pre-installed programmes and 4 user-set programmes
- "Self-learning" temperature control
- Child lock
- Low battery alarm
- Unlimited programme memory in the case of discharged batteries

Product	Description
RID-WL	Timed thermostat including receiver

### Additional relay device

Additional relay device, with a maximum of 6 devices which can be controlled by the same RID-WL timed thermostat



- Degree of protection:** IP30
- Frequency:** 868 MHz
- Powered receiver:** 230 V, 50 Hz
- Relay range:** 8 A
- Range in distance:** 100 m outdoors, 30 m indoors

Product	Description
RID-WL-R	Additional receiver for loads greater than 8 A