

# HEATING CABLES

INDUSTRIAL USE.  
DOMESTIC USE.  
COMFORT HOUSE.

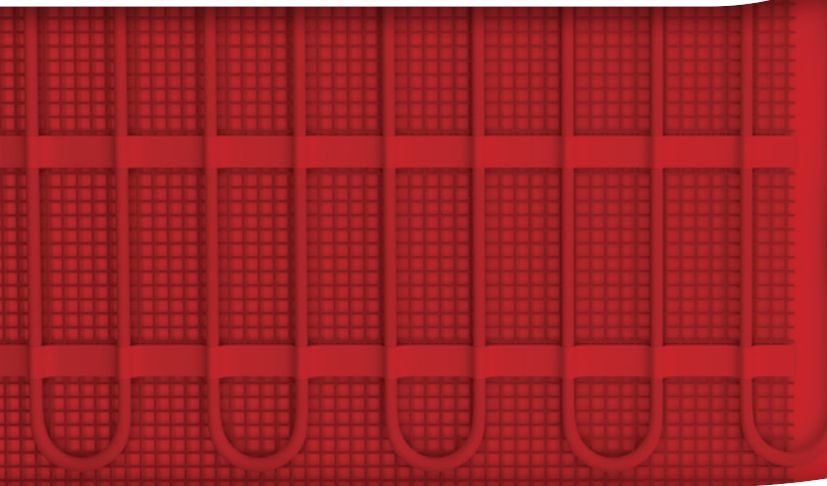

# Heating Cables

Heating cables are used for frost protection of pipes, tanks, ramps and walkways, gutters, etc., or for maintaining process temperatures, especially in industrial environments.

- **CONSTANT POWER CABLES**
- **SELF-REGULATING CABLES**

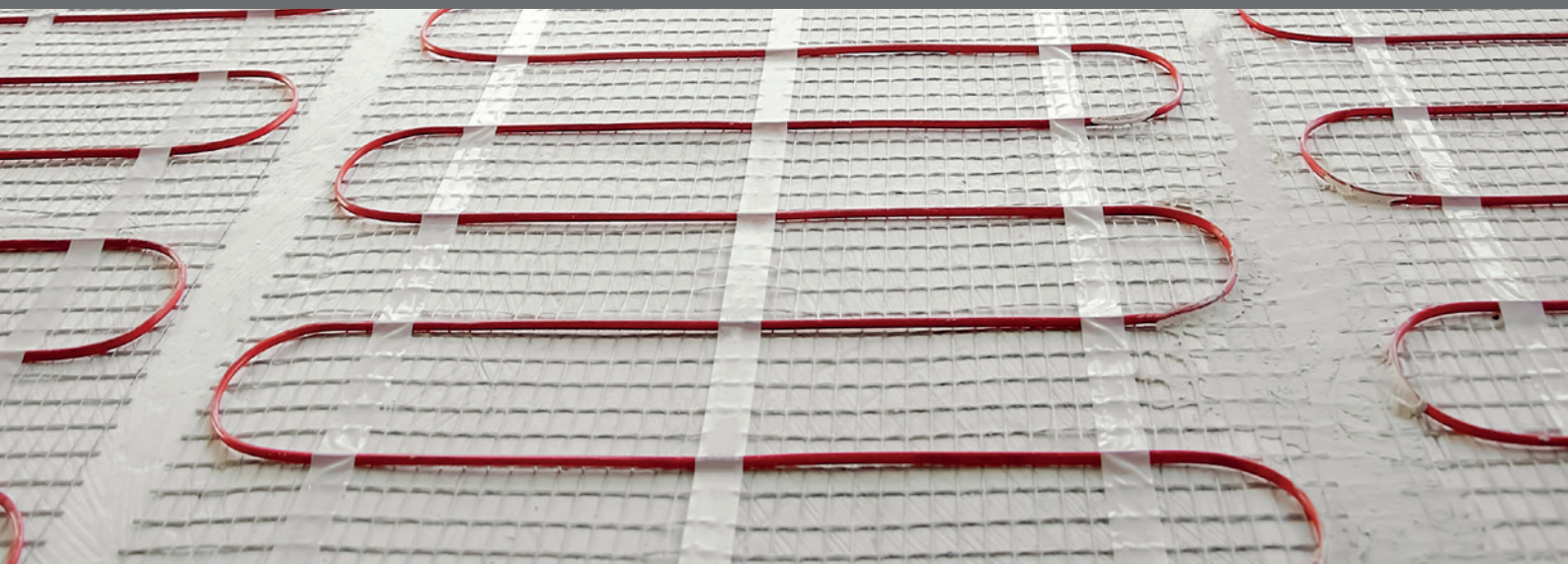

## CONSTANT POWER CABLES

Raytech cables are composed of 2 conductors that are shielded and in the case of Stop Ice are supplied with a suitable thermostat for anti-freeze maintenance.



### ★ ADVANTAGES CONSTANT POWER CABLES

- **Ready for use**, without requiring the installation of accessories.
- **Already equipped with a thermostat**, in the case of Stop Ice.
- **Completely reliable.**

## SELF-REGULATING CABLES

The self-regulation technology and the parallel circuit present the following advantages:

- The heating cables can be cut at the desired length, jointed and terminated on site.
- They can be supplied at 230 V without transformers.
- They can be overlapped without over heating risks.
- They reduce automatically their power output as the required temperature is reached.
- They are easy designed and can be easily handled on site.

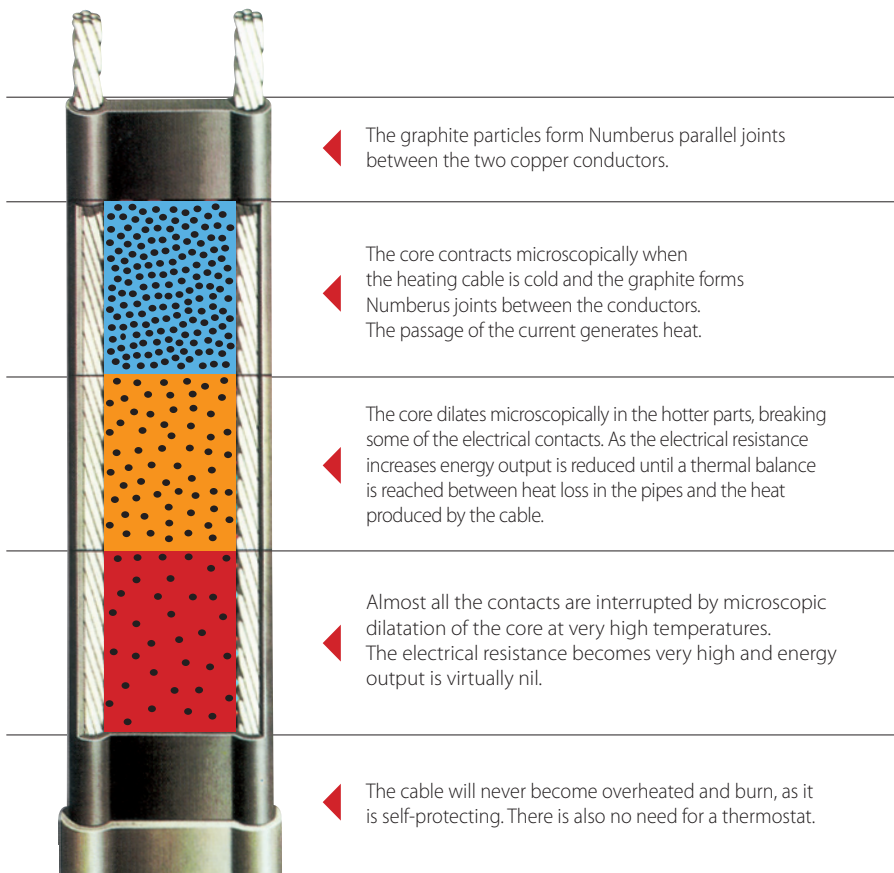

### ★ ADVANTAGES SELF-REGULATING CABLES

- **A reduction in overall installation costs**
- **Reduction in operating cost**
- **Very easy to install**
- **Simple design**
- **Uniform temperature**
- **Complete reliability**



# HEATING CABLES INDUSTRIAL USE

## MCA / MCA-I-PF

CABLE POWERED  
From -55°C to +65°C

CABLE NOT POWERED  
From -55°C to +80°C



## MCA-I-GF

CABLE POWERED  
From -60°C to +120°C

CABLE NOT POWERED  
From -60°C to +120°C



## MCA-I-FF

CABLE POWERED  
From -60°C to +110°C

CABLE NOT POWERED  
From -60°C to +130°C



# MCA

**Self-regulating** heating cables for anti-freeze or temperature maintenance use with exposure to **mild inorganic solutions**.

Suitable for anti-freeze and process temperature maintenance use **up to 65°C** on piping and tanks. Cannot be used when washing with steam or continuous exposure to strong corrosive and organic acids.

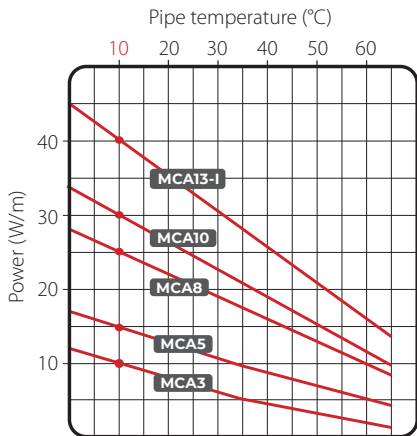

**CONSTITUTION OF THE CABLE**

- Copper conductors
- Self regulating conductive core
- Modified polyolefine insulation
- Copper screen
- Modified polyolefine outer sheath

**Cables certified for classified zones**

Ex II 2G Ex 60079-30-1 IIC Gb  
Ex II 2D Ex 60079-30-1 IIIC Db  
In accordance: EN IEC 60079-0:2018  
EN IEC 60079-30-1:2017



**Type of surface to be tracked:**  
Steel - Painted - Stainless Steel - Plastic.  
**Chemical resistance:**  
Suitable for exposure to mild inorganic solutions.

Product	Power voltage (V)	Power at 10°C (W/m)	Minimum installation temperature (°C)	MAX Temperature Continuous with powered cable (°C)	MAX Temperature with no powered cable (°C)	Bending radius MIN (mm)	Temperature classification
MCA3	230	10	-55	65	80	25	T6
MCA5		15					
MCA8		25					
MCA10		30					
MCA13-I		40					

ELECTRICAL SIZING	Starting temperature (°C)	MAXIMUM LENGTH OF THE CIRCUITS IN THE HEATING CABLE (m)														
		MCA3			MCA5			MCA8			MCA10			MCA13-I		
		+10°	-10°	-20°	+10°	-10°	-20°	+10°	-10°	-20°	+10°	-10°	-20°	+10°	-10°	-20°
Switchgear protection (A), with C curve and 30mA* differential protection*	10 A	-	-	-	103	71	62	64	47	37	49	38	33	-	-	-
	16 A	177	144	125	160	114	99	103	75	60	78	61	53	57	44	40
	20 A	-	149	139	-	133	124	126	94	75	97	76	66	71	55	50
	25 A	-	-	-	-	-	-	-	107	94	112	95	83	89	69	62

\* Suggested where protection of people is requested; installations with no personnel admittance can be performed with 100 to 300 mA.

**MCA connection accessories**

<p><b>MCA Universal IP68</b></p> <ul style="list-style-type: none"> <li>• Connection kit integrated with the terminal box.</li> <li>• Termination Kit.</li> <li>• Joint Kit.</li> </ul>	<p><b>MCA-Y</b> Branch Kit.</p>	<p><b>MCA-BOX3 / 4</b> Connection boxes between heating cables or heating and power cables.</p>	<p><b>MCA-AL</b> Thermal insulation pass-through kit.</p>	<p><b>MCA-PRESS</b> Cable gland.</p>	<p><b>MCA-EA</b> Warning label.</p>	<p><b>MCA-FV</b> Glass fiber tape.</p>	<p><b>MCA-ALL</b> Aluminium self adhesive tape 25 or 75 mm.</p>
---	-------------------------------------	---	---	--	---	--	---

For other accessories see page 229

# MCA-I-PF

**Self-regulating** heating cables for anti-freeze or temperature maintenance use with exposure to **inorganic solutions**.

Suitable for anti-freeze and process temperature maintenance use **up to 65°C** on piping and tanks. Cannot be used when washing with steam or continuous exposure to strong corrosive and organic acids.



### CONSTITUTION OF THE CABLE

- Copper conductors
- Self regulating conductive core
- Modified polyolefine insulation
- Copper screen
- Fluoropolymer outer sheath

### Cables certified for classified zones

Ex II 2G Ex 60079-30-1 IIC Gb  
Ex II 2D Ex 60079-30-1 IIIC Db  
In accordance: EN IEC 60079-0:2018  
EN IEC 60079-30-1:2017



### Type of surface to be tracked:

Steel - Painted - Stainless Steel - Plastic.

### Chemical resistance:

Suitable for exposure to mild inorganic solutions.

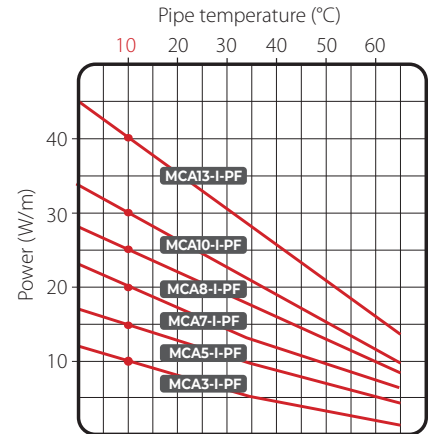

Product	Power voltage (V)	Power at 10°C (W/m)	Minimum installation temperature (°C)	MAX Temperature Continuous with powered cable (°C)	MAX Temperature with no powered cable (°C)	Bending radius MIN (mm)	Temperature classification
MCA3-I-PF	230	10	-55	65	80	25	T6
MCA5-I-PF		15					T6
MCA7-I-PF		20					T6
MCA8-I-PF		25					T5
MCA10-I-PF		30					T5
MCA13-I-PF		40					T6

ELECTRICAL SIZING	MAXIMUM LENGTH OF THE CIRCUITS IN THE HEATING CABLE (m)																		
	MCA3-I-PF			MCA5-I-PF			MCA7-I-PF			MCA8-I-PF			MCA10-I-PF			MCA13-I-PF			
Starting temperature (°C)	+10°	-10°	-20°	+10°	-10°	-20°	+10°	-10°	-20°	+10°	-10°	-20°	+10°	-10°	-20°	+10°	-10°	-20°	
Switchgear protection (A), with C curve and 30mA* differential protection*	10 A	202	202	163	153	144	115	109	79	70	91	86	70	57	54	44	57	44	40
	16 A	202	202	202	165	165	144	129	99	87	120	107	87	76	67	55	71	55	50
	20 A	202	202	202	165	165	165	-	111	104	128	128	109	95	84	69	89	69	62
	25 A	202	202	202	165	165	165	-	-	-	128	128	128	97	97	88	-	-	-

\* Suggested where protection of people is requested; installations with no personnel admittance can be performed with 100 to 300 mA.

## MCA-I-PF connection accessories

<p><b>MCA Universal IP68</b></p> <ul style="list-style-type: none"> <li>• Connection kit integrated with the terminal box.</li> <li>• Termination Kit.</li> <li>• Joint Kit.</li> </ul>	<p><b>MCA-Y</b> Branch Kit.</p>	<p><b>MCA-BOX3 / 4</b> Connection boxes between heating cables or heating and power cables.</p>	<p><b>MCA-AL</b> Thermal insulation pass-through kit.</p>	<p><b>MCA-PRESS</b> Cable gland.</p>	<p><b>MCA-EA</b> Warning label.</p>	<p><b>MCA-FV</b> Glass fiber tape.</p>	<p><b>MCA-ALL</b> Aluminium self adhesive tape 25 or 75 mm.</p>
---	-------------------------------------	---	---	--	---	--	---

For other accessories see page 229

# MCA-I-GF

**Self-regulating** heating cables for anti-freeze or temperature maintenance use with exposure to **corrosives and acids**.

Suitable for maintaining process temperatures **up to 120°C** on piping and tanks, even in the presence of acids and corrosives, or for anti-freeze use where acids and corrosives are present, in safe areas. Not suitable for use in the presence of steam washing.

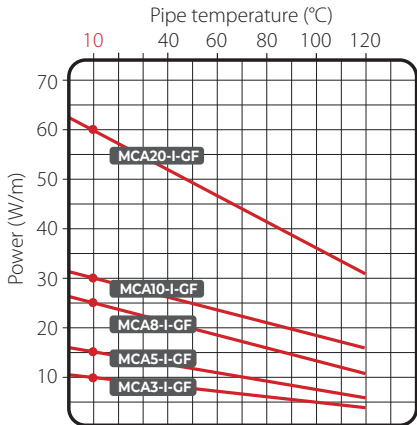

**CONSTITUTION OF THE CABLE**

- Copper conductors
- Self regulating conductive core
- Fluoropolymer insulation
- Copper screen
- Modified polyolefine outer sheath

**Type of surface to be tracked:**  
Steel - Painted - Stainless Steel.

**Chemical resistance:**  
Suitable for exposure to corrosive and organic acids.

Product	Power voltage (V)	Power at 10°C (W/m)	Minimum installation temperature (°C)	MAX Temperature Continuous with powered cable (°C)	MAX Temperature with no powered cable (°C)	Bending radius MIN (mm)
MCA3-I-GF	230	10	-60	120	120	25
MCA5-I-GF		15				
MCA8-I-GF		25				
MCA10-I-GF		30				
MCA20-I-GF		60				

ELECTRICAL SIZING	Starting temperature (°C)	MAXIMUM LENGTH OF THE CIRCUITS IN THE HEATING CABLE (m)														
		MCA3-I-GF			MCA5-I-GF			MCA8-I-GF			MCA10-I-GF			MCA20-I-GF		
		+10°	-15°	-25°	+10°	-15°	-25°	+10°	-15°	-25°	+10°	-15°	-25°	+10°	-15°	-25°
Switchgear protection (A), with C curve and 30mA* differential protection*	16 A	200	180	175	165	130	117	120	97	88	85	73	69	50	41	38
	20 A	235	235	235	189	162	152	140	125	120	114	98	92	64	55	52
	30 A	-	-	-	-	-	189	-	-	140	-	-	114	-	-	64

\* Suggested where protection of people is requested; installations with no personnel admittance can be performed with 100 to 300 mA.

**MCA-I-GF connection accessories**

<p><b>MCA Universal IP68</b></p> <ul style="list-style-type: none"> <li>• Connection kit integrated with the terminal box.</li> <li>• Termination Kit.</li> <li>• Joint Kit.</li> </ul>	<p><b>MCA-Y</b> Branch Kit.</p>	<p><b>MCA-BOX3 / 4</b></p> <p>Connection boxes between heating cables or heating and power cables.</p>	<p><b>MCA-AL</b></p> <p>Thermal insulation pass-through kit.</p>	<p><b>MCA-PRESS</b></p> <p>Cable gland.</p>	<p><b>MCA-EA</b></p> <p>Warning label.</p>	<p><b>MCA-FV</b></p> <p>Glass fiber tape.</p>	<p><b>MCA-ALL</b></p> <p>Aluminium self adhesive tape 25 or 75 mm.</p>
---	-------------------------------------	--	--	---	--	---	--

For other accessories see page 229

# MCA-I-FF

**Self-regulating** heating cables for anti-freeze or temperature maintenance use with exposure to **corrosives and acids and high temperatures.**

Suitable for maintaining process temperatures **up to 110°C** on piping and tanks, even in the presence of acids and corrosives, or for anti-freeze use even in the presence of acids and corrosives and where high temperature thermal treatment is foreseen, like steam washing.



### CONSTITUTION OF THE CABLE

Copper conductors
Self regulating conductive core
Fluoropolymer insulation
Copper screen
Fluoropolymer outer sheath

### Cables certified for classified zones

Ex II 2G Ex 60079-30-1 IIC Gb  
Ex II 2D Ex 60079-30-1 IIIC Db  
In accordance: EN IEC 60079-0:2018  
EN IEC 60079-30-1:2017



### Type of surface to be tracked:

Steel - Painted - Stainless Steel - Plastic.

### Chemical resistance:

Suitable for exposure to corrosives and acids and high temperatures.

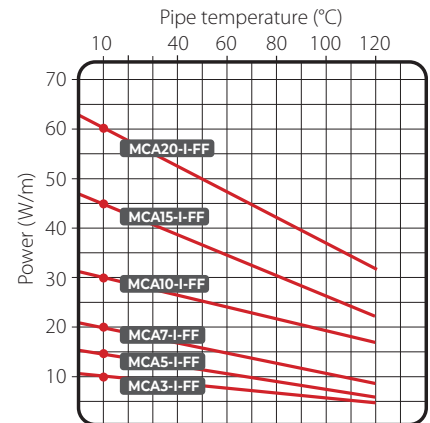

Product	Power voltage (V)	Power at 10°C (W/m)	Minimum installation temperature (°C)	MAX Temperature Continuous with powered cable (°C)	MAX Temperature with no powered cable (°C)	Bending radius MIN (mm)	Temperature classification
MCA3-I-FF	230	10	-60	110	130	25	T4
MCA5-I-FF		15					T4
MCA7-I-FF		20					T3
MCA10-I-FF		30					T3
MCA15-I-FF		45					T3
MCA20-I-FF		60					T3

ELECTRICAL SIZING	MAXIMUM LENGTH OF THE CIRCUITS IN THE HEATING CABLE (m)																		
	MCA3-I-FF			MCA5-I-FF			MCA7-I-FF			MCA10-I-FF			MCA15-I-FF			MCA20-I-FF			
Starting temperature (°C)	+10°	0°	-20°	+10°	0°	-20°	+10°	-15°	-25°	+10°	0°	-20°	+10°	-15°	-25°	+10°	-0°	-20°	
Switchgear protection (A), with C curve and 30mA* differential protection*	16 A	230	217	195	164	155	141	122	107	102	92	87	79	55	48	36	52	49	45
	20 A	231	231	231	188	188	177	136	127	124	115	109	98	68	60	57	65	61	56
	25 A	231	231	231	188	188	188	-	-	-	133	133	123	-	-	-	75	75	70
	32 A	231	231	231	188	188	188	-	-	-	133	133	133	91	83	82	75	75	75

\* Suggested where protection of people is requested; installations with no personnel admittance can be performed with 100 to 300 mA.

## MCA-I-FF connection accessories

<p><b>MCA Universal IP68</b></p> <ul style="list-style-type: none"> <li>• Connection kit integrated with the terminal box.</li> <li>• Termination Kit.</li> <li>• Joint Kit.</li> </ul>	<p><b>MCA-Y</b> Branch Kit.</p>	<p><b>MCA-BOX3 / 4</b> Connection boxes between heating cables or heating and power cables.</p>	<p><b>MCA-AL</b> Thermal insulation pass-through kit.</p>	<p><b>MCA-PRESS</b> Cable gland.</p>	<p><b>MCA-EA</b> Warning label.</p>	<p><b>MCA-FV</b> Glass fiber tape.</p>	<p><b>MCA-ALL</b> Aluminium self adhesive tape 25 or 75 mm.</p>
---	-------------------------------------	---	---	--	---	--	---

For other accessories see page 229



# HEATING CABLES DOMESTIC USE

## PIPING

CONSTANT POWER



STOP ICE

SELF-REGULATING



ICE KILLER  
MCA

## RAMPS

CONSTANT POWER



EASY CABLE  
EASY RAMP

SELF-REGULATING



MCA RAMP

## GUTTERS

CONSTANT POWER



EASY FROST

SELF-REGULATING



MCA 8



**CHARACTERISTICS**

**Power:** 12 W/m  
**Power supply:** 230 V – 50 Hz  
**Cable dimensions:** ~ 5x7 mm  
**Min. installation temperature:** +5°C  
**Max. working temperature:** +70°C  
**Heating cable type:**  
 2 conductors, screened cable  
**Insulation:** XLPE  
**External sheath:** PVC  
**Min. bending radius:** 3,5 D  
**Protection degree:** IP X7  
**Marking:** CE



Integrated Bimetal Thermostat  
(ON + 3°C - OFF +10°C)



Complete Connections and power cord  
(1,5 m - 3 x 0,75 mm²)

# STOP ICE

**Constant power** anti-freeze kit complete with thermostat and plug.

Raytech Stop Ice is a pre-assembled kit consisting of a constant wattage heating cable of 12 W/m, complete with contact thermostat (installed on the end of the heating cable) and power cable with plug. Stop-Ice is particularly suitable for frost protection, and prevention of possible damages caused by low temperatures on pipes, valves, faucets, water meters, troughs, bowls and small tanks.

- Easy and quick to install
- No need for any external temperature control system, thanks to its built-in thermostat
- Low energy consumption

Product	Power (W/kit)	Specific power (W/m)	Length (m)
Stop Ice 2/12	24	12	2
Stop Ice 5/12	60	12	5
Stop Ice 10/12	120	12	10
Stop Ice 18/12	216	12	18

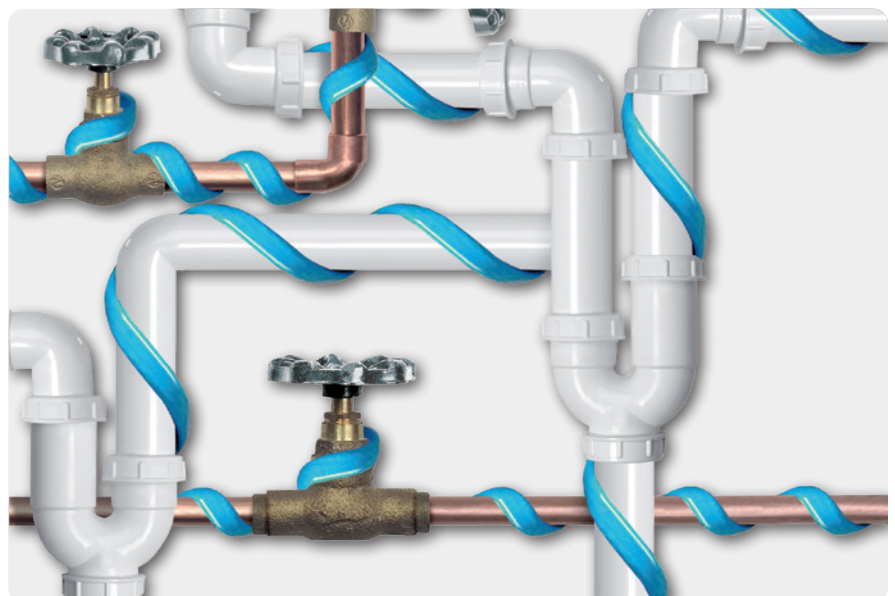

# LINUS

Self-adhesive thermal insulating tape.

To offer a complete solution in the field of electrical tracking, Raytech has developed, LINUS, an insulation tape to maintain temperature. The product is a closed-cell expanded synthetic rubber, low thermal conductivity and extremely flexible tape. The rubber tape is coupled with an aluminium sheet to protect against tearing, for greater resistance to perforation and higher tensile resistance. It also protects very well against UV radiation. The tape is self-adhesive for easy application on traced pipes. The closed cells and the special material type give the tape very high insulating properties and optimal behaviour in the presence of condensation.

Product	Width (mm)	Thickness (mm)		Length (m)
LINUS	50	3		10
<b>LENGTH PIPE</b> I can insulate with 1 LINUS tape 50% overlapped		pipe Ø ¾" (DN 20)	pipe Ø 1" (DN 25)	pipe Ø 1 ¼" (DN 32)
		2,2 m	1,9 m	1,6 m



50 mm

3 mm

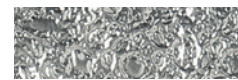

### CHARACTERISTICS

**Density:** 0,7

**Temperature range:** -50°C -105°C

**Coefficient of thermal conductivity (λ):** 0,039 W/mK a 50°C

**Flame resistance:** Bs3-d0  
(DIN EN 13501-1)

# STOP ICE PLUS

**Constant power** anti-freeze kit complete with thermostat, connection plug and insulation tape.

### STOP ICE + LINUS

- Stop Ice 12 W/m constant power cable, complete with connection plug and thermostat
- 3 mm LINUS insulation tape, for application on already traced pipe with a cable, to apply with 50% overlap

As an example, with a 10 m long LINUS tape, about 2.2 m of ¾", traced with the Stop Ice cable, can be insulated.

HEATING CABLE  
BUILT-IN THERMOSTAT  
BUILT-IN PLUG



TAPE INSULATION  
TO MAINTAIN  
TEMPERATURE

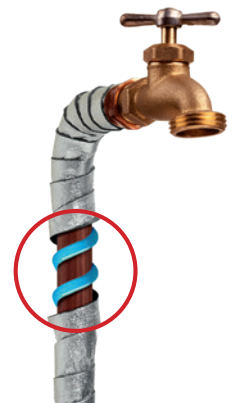

### CABLE

**Specific power:** 12 W/m

**Power supply:** 230 V- 50Hz

**Cold cable:** 3 x 0,75 mm<sup>2</sup> - L = 1,5 m

**Temperature control:** integrated bimetallic thermostat

**ON / OFF:** +3°C / +10°C

### INSULATION TAPE

**Temperature range:** -50 / +105°C

**Coefficient of thermal conductivity (λ):** 0,039 W/mK a 50°C

**Dimensions:** 50 mm x 3 mm x L10 m

Product	Power (W/kit)	Length cable (m)
Stop Ice Plus 2	24	2
Stop Ice Plus 5	60	5

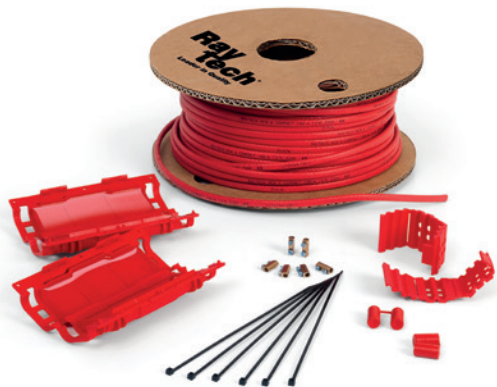

Supply voltage: 230 V  
 Min installation temperature: -30°C  
 Cable dimensions: 7,7 x 5,3 mm  
 Max temperature with powered cable: 65°C  
 Max exposure temperature with non-powered cable: 65°C

# ICE KILLER

Cut and install **self-regulating** cable kit, complete with connection side and termination kit.

The Ice Killer kit is composed of a 30 m self-regulating cable coil, complete with connection side and termination accessories. The cable can be cut to the desired length, installed on the pipe or tank, connected to the mains and terminated at the opposite end. The economic and compact Ice Killer kit is sold in an attractive, easy to carry, easy to handle on-site package, is small in size, very flexible and can be easily adapted to bends in the pipe.

The Ice Killer cable is laid linearly or wound around the pipe, depending on the specific necessary power. It is then fastened to the same by means of inextensible tape (Raytech MCA-FV or MCA-ALL75 type tapes), terminated with accessories contained in the kit and then clad with the insulation. Operating temperature is reached very quickly and is maintained almost constant even with room temperature variations.

Product	Specific power a 10°C (W/m)	Kit composition			
		Maximum circuit length (m)			
Ice Killer 2	10	30 m cable Connection accessory Termination accessory			
Ice Killer 6	18	30 m cable Connection accessory Termination accessory			
Starting temperature	Ice Killer 2		Ice Killer 6		
	0°C	-20°C	0°C	-20°C	
10 A electrical protection, characteristic C switch with differential 30 mA protection	95	77	58	41	



# MCA

**Self-regulating** cable for anti-freeze use or for maintaining temperatures for general use.

For anti-freeze use on pipes or tanks or for maintaining process temperatures under 65°C, even in hazardous areas. Maintenance-free, reliable, easy to install. Suitable even in the presence of mild inorganic solutions.



Product	Power voltage (V)	Minimum installation temperature (°C)	Power at 10°C (W/m)	TEMPERATURE MAX	
				Continuous cable powered (°C)	Intermittent cable not powered (°C)
MCA3	220-240	-30	10	65	80
MCA5	220-240	-30	15	65	80
MCA8	220-240	-30	25	65	80

ELECTRICAL SIZING		MAXIMUM LENGTH OF THE CIRCUITS IN THE HEATING CABLE (m)								
		MCA3			MCA5			MCA8		
Starting temperature (°C)		+10°	-10°	-20°	+10°	-10°	-20°	+10°	-10°	-20°
Switchgear protection (A), with C curve and 30mA* differential protection*	10 A	-	-	-	103	71	62	64	47	37
	16 A	177	144	125	160	114	99	103	75	60
	20 A	-	149	139	-	133	124	126	94	75
	25 A	-	-	-	-	-	-	-	107	94

\* Suggested where protection of people is requested; installations with no personnel admittance can be performed with 100 to 300 mA.









Pipe Ø		Thermal insulation thickness									
		10 mm		20 mm		30 mm		40 mm		50 mm	
		Outer temperature (°C)									
inch	mm	-10	-20	-10	-20	-10	-20	-10	-20	-10	-20
1/2"	15	1-3	1-3	1-3	1-3	1-3	1-3	1-3	1-3	1-3	1-3
3/4"	20	1-3	1-3	1-3	1-3	1-3	1-3	1-3	1-3	1-3	1-3
1"	25	1-3	1-8	1-3	1-3	1-3	1-3	1-3	1-3	1-3	1-3
1¼"	32	1-3	1-8	1-3	1-3	1-3	1-3	1-3	1-3	1-3	1-3
1½"	40	1-3	1-8	1-3	1-3	1-3	1-3	1-3	1-3	1-3	1-3
2"	50	1-8	1-8	1-3	1-8	1-3	1-3	1-3	1-3	1-3	1-3
2½"	65	1-8	1-8	1-3	1-8	1-3	1-3	1-3	1-3	1-3	1-3
3"	80	1-8	2-8	1-3	1-8	1-3	1-5	1-3	1-3	1-3	1-3
4"	100	1-8	2-8	1-5	1-8	1-3	1-5	1-3	1-5	1-3	1-3
6"	150	2-8	2-8	1-8	2-8	1-8	1-8	1-3	1-8	1-3	1-8
8"	200	2-8	-	1-8	2-8	1-8	1-8	1-8	1-8	1-3	1-8
10"	250	2-8	-	2-8	-	1-8	2-8	1-8	1-8	1-8	1-8

### HOW TO CHOOSE MCA CABLE FOR ANTIFREEZE PROTECTION

The table gives the cable quantity for tube length unit (1st number) and the MCA cable code number (2nd number) versus tube diameter, thermal insulation thickness (for rockwool) and min outer temperature.

For uses other than anti-freeze, request design from Raytech technical direction.

### MCA connection accessories

 <p><b>MCA Universal IP68</b></p> <ul style="list-style-type: none"> <li>• Connection kit integrated with the terminal box.</li> <li>• Termination Kit.</li> <li>• Joint Kit.</li> </ul>	 <p><b>MCA-Y</b> Branch Kit.</p>	 <p><b>MCA-BOX3 / 4</b></p> <p>Connection boxes between heating cables or heating and power cables.</p>	 <p><b>MCA-AL</b></p> <p>Thermal insulation pass-through kit.</p>	 <p><b>MCA-PRESS</b></p> <p>Cable gland.</p>	 <p><b>MCA-EA</b></p> <p>Warning label.</p>	 <p><b>MCA-FV</b></p> <p>Glass fiber tape.</p>	 <p><b>MCA-ALL</b></p> <p>Aluminium self adhesive tape 25 or 75 mm.</p>
---	---	--	--	--	--	---	--

For other accessories see page 229

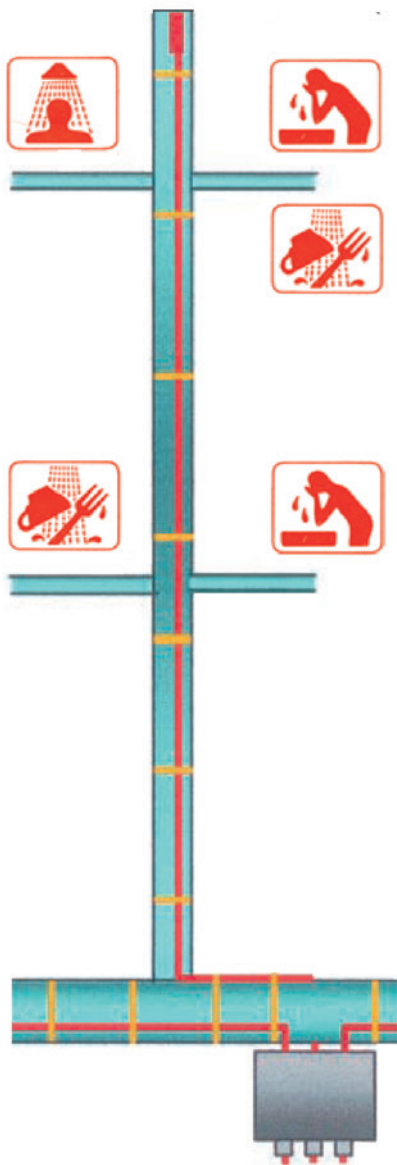

# MCA

**Self-regulating** cable for pipe tracing for domestic hot water.

The tracing of domestic hot water systems allows you to always have the water at the ideal temperature available at each pick up point: this allows an energy saving (approximately up to 70%) also for the elimination of thermal losses in recirculation pipes. The pipes must always be insulated with suitable thermal insulation; for the choice and the project, please contact Raytech.

		MCA3	MCA5	MCA8	MCA10-IGF
TEMPERATURE (°C)	max operating	65°	65°	65°	120°
	max exposure*	80°	80°	80°	120°
	maintenance**	45°	55°	60°	80°
Available power	a 40°C (W/m)	6	8	14	25
Max length to be supplied with starting at 10°C through a switchgear	16 A	177	160	103	85
	20 A	-	-	126	114
	30 A	-	-	126	-
RECOMMENDED FOR		Small villas	Blocks of flats Buildings	Blocks of flats Buildings	Hotels Hospitals

\*Circuit breakers with "C" curve, with a 30 mA differential.

\*\*The indicated data is the limit maintenance temperature for which the cable can be used; for insulation sizing, please contact Raytech.

## MCA connection accessories



- MCA Universal IP68**
- Connection kit integrated with the terminal box.
  - Termination Kit.
  - Joint Kit.



- MCA-Y**  
Branch Kit.



- MCA-BOX3 / 4**  
Connection boxes between heating cables or heating and power cables.



- MCA-AL**  
Thermal insulation pass-through kit.



- MCA-PRESS**  
Cable gland.



- MCA-EA**  
Warning label.



- MCA-FV**  
Glass fiber tape.



- MCA-ALL**  
Aluminium self adhesive tape 25 or 75 mm.

For other accessories see page 229

# EASY CABLE

**Constant**, versatile power heating cable complete with termination accessory and power cable.

Especially suitable for solving anti-freeze problems: snow or ice accumulation on access ramps, walkways and stairs, or for frost protection of pipes or tanks, under adequate insulation. 3 standard lengths are available, with a specific power of 25 W/m, covering all possible tracking types. Complete with termination accessory and power cable, Easy cable is a shielded heating cable under a protective sheath with two conductors, with extremely simple and quick installation and connection. Please note that the cable should never be cut, spliced or overlapped.

FOR RAMPS	Specific power (W/m)	Rated power (W)	Maximum length for each individual wheel passage	
Product			40 cm (A) 4 passages	50 cm (B) 5 passages
Easy Cable 26/25 Length 26,5 m	25	655	6 m	5 m
Easy Cable 44/25 Length 44 m	25	1120	10,5 m	8,5 m
Easy Cable 92/25 Length 92 m	25	2270	22,5 m	18 m

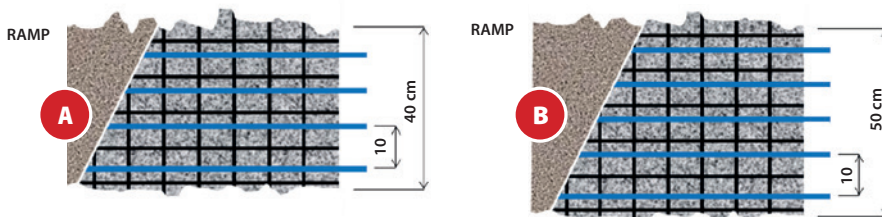

Depth of installation about 50 mm with respect to the surface.

PER PIPING	Specific power (W/m)	Rated power (W)	Anti-freeze for pipes up to 2 1/2" (Dn 65 mm), for minimum temperatures up to -15°C, with rock wool thickness	Anti-freeze for pipes from 3" (Dn 80) up to 6" (Dn 200 mm), for minimum temperatures up to -15°C, with rock wool thickness
Product				
Easy Cable 26/25 Length 26,5 m	25	655	10 mm	20 mm
Easy Cable 44/25 Length 44 m	25	1120	10 mm	20 mm
Easy Cable 92/25 Length 92 m	25	2270	10 mm	20 mm

Anti-freeze tracking for piping, longitudinal linear installation 1 m cable/m pipe.

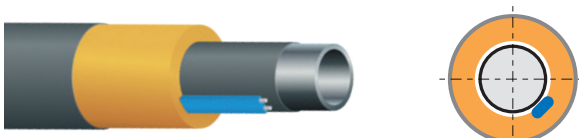

## CHARACTERISTICS

- Power supply:** 230 V, 50/60 Hz
- Cable dimensions:** ~ 5x7 mm
- Min. installation temperature:** +5°C
- Max. working temperature:** +80°C
- Heating cable type:** 2 conductors, screened cable
- Specific power:** 25 W/m
- Insulation:** XLPE
- External sheath:** PVC
- Marking:** CE

## Control unit for Easy Cable for ramps.



### C2000

he C 2000 control unit, to be completed with the C2000-SR temperature, snow and humidity sensor (sensor to be placed flush with the ramp and to be ordered separately from the control unit), activating the power contactor, gives consent to start the system only when low temperature and snow or ice are present simultaneously, optimising energy consumption.



### C2000-SR

Temperature, snow and humidity sensor



**ATTENTION:** since it is a constant power cable, the *EASY CABLE* can not be cut, jointed or overlapped.



**CHARACTERISTICS**

**Mat specific power:** 300 W/m<sup>2</sup>

**Power supply:** 230 V ~ 50/60 Hz

**Mat thickness:** 7,5 mm

**Min. installation temperature:** + 5°C

**Max. working temperature:** + 80°C

**Cold cable (supply):**

length 4 meters - 3 x 1,5 mm<sup>2</sup> or 3x2,5 mm<sup>2</sup>

**Heating cable type:**

2 conductors, screened cable

**Heating cable dimensions:** ~ 5 x 7 mm

**Heating cable power:** 25 W/m

**Insulation:** XLPE

**External sheath:** PVC

**Marking:** CE



# EASY RAMP

**Constant wattage** heating mat.

Raytech Easy Ramp consists of a constant wattage heating cable assembled with tape to form a heating mat, which is easily and quickly spread on the surfaces to be protected. Easy Ramp is ideal for solving the problems caused by ice formation and the accumulation of snow on the access ramps to garages, pathways, outdoor parking areas, footpaths, etc. It can be installed in concrete, asphalt, and interlocking bricks or under porphyry paving or other paving materials blocked with cement and sand. The standard width of Easy Ramp pads is 60 cm; a sufficient width to free the track of vehicle wheels from ice and snow or to create an extremely safe pedestrian pathway.

The power density developed by Easy Ramp is 300 W/m<sup>2</sup>. The mat is available in various lengths which are easily adaptable to the size of the area to track and where the size of the mat is larger than that of the ramp, the excess part of mat can be easily folded 90 degrees. The mat is supplied completely finished and ready for installation, complete with 4 meters of cold cable (3x1.5 mm<sup>2</sup> or 3x2.5 mm<sup>2</sup>) for connection to the power supply. The constant wattage heating cable, which constitutes the mat, is a 2 conductor heating cable, which is shielded; this allows one end only to be powered, making installation even faster and easier.

Product	Power (W)	Specific power (W/m <sup>2</sup> )	Width (m)	Length (m)
Easy Ramp 4/300	670	300	0,6	4
Easy Ramp 7/300	1140	300	0,6	7
Easy Ramp 13/300	2560	300	0,6	13
Easy Ramp 21/300	3730	300	0,6	21



**ATTENTION:** since it is a constant power cable, the *EASY RAMP* can not be cut, jointed or overlapped.

RAMPS - STEPS - DRIVEWAYS - PARKING  
WALKWAYS - TERRACES - BALCONIES

# MCA RAMP

## Self-regulating heating cable.

The cable is used, buried in concrete, to prevent the accumulation of ice and its formation on access ramps, stairs, sidewalks, parking lots, walkways, etc. Suitable for ramps covered in concrete, interlocking brick or asphalt, both for light and heavy traffic. The cable can be installed on ramps under construction, securing the electrowelded mesh prior to pouring of the concrete, or else on already completed ramps by cutting the concrete surfaces to then fill with plastic cement after installation of the cable, or simply by laying the cable on the surface of the ramp and throwing another layer of cement.

### Cable roofing cement or interlocking, asphalt, gneiss, and any other material

Product	Power at 0°C in concrete (W/m)	Max working temperature (°C)	Cable length	
			Switgear*	Maximum length (m)
MCA 20-I-GF	90	120	40 A	64
MCA 10**	50	65	40 A	90

\* Differential protection 30 mA

\*\*For ramps, stairs etc. with ambient temperature not lower than -15°C; for lower temperatures use only MCA 20-I-GF cable. For draining trenches tracing MCA8 cable shall be used. For other information contact Raytech.

Notes: to trace drain outlets, use the MCA8 cable installed on the bottom of the outlets under the grate.

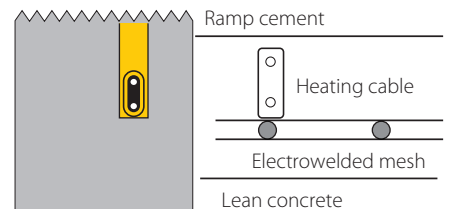

### Control unit for Easy Ramp and MCA Ramp



**C2000**  
The C 2000 control unit, to be completed with the C2000-SR temperature, snow and humidity sensor (sensor to be placed flush with the ramp and to be ordered separately from the control unit), activating the power contactor, gives consent to start the system only when low temperature and snow or ice are present simultaneously, optimising energy consumption.



**C2000-SR**  
Temperature, snow and humidity sensor.

### MCA Ramp connection accessories



**MCA Universal IP68**

- Connection kit integrated with the terminal box.
- Non-powered side terminal kit.
- Joint Kit.



**MCA-BOX3 / 4**  
Connection boxes between heating cables or heating and power cables.



**MCA-PRESS**  
Cable gland.

For other accessories see page 229



**Power:** 20 W/m  
**Power supply:** 230 V ~ 50/60 Hz  
**Heating cable dimensions:** ~ 5 x 7 mm  
**Min. installation temperature:** + 5°C  
**Max. working temperature:** + 80°C  
**Cold cable (power supply):**  
 length 4 meters - 3 x 1,0 mm<sup>2</sup> or 3 x 1,5 mm<sup>2</sup>  
**Heating cable type:**  
 2 conductors, screened cable  
**Insulation:** XLPE  
**External sheath:** PVC  
**Min. bending radius:** 3,5 D  
**Marking:** CE

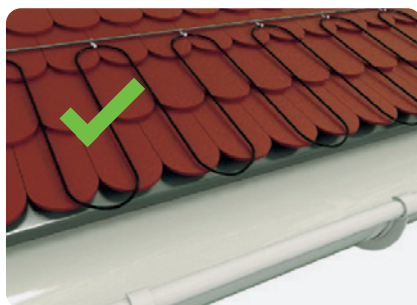

# EASY FROST

**Constant power** heating cable for roofs, gutters and downpipes.

Raytech Easy Frost is a 20W/m constant power cable especially designed for roofs, gutters and downpipe protection from damage due to snow accumulation and ice formation. Easy Frost is supplied terminated and ready for installation, with 4 metres of cold cable (3 x 1,0 mm<sup>2</sup> o 3 x 1,5 mm<sup>2</sup>) for supply connection.

Product	Power (W)	Specific power (W/m)	Resistance (Ω)	Length (m)
Easy Frost 50/20	1000	20	52,9	50
Easy Frost 102/20	2040	20	29,9	102



## Control unit for EASY FROST



### C2000

The C2000 control unit, to be completed with the C2000-SR temperature, snow and humidity sensor (sensor to be placed flush with the ramp and to be ordered separately from the control unit), activating the power contactor, gives consent to start the system only when low temperature and snow or ice are present simultaneously, optimising energy consumption.

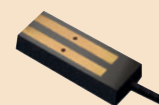

### C2000-SUG

Ice and snow sensor.



### C2000-STG

Temperature sensor.



**ATTENTION:** since it is a constant power cable, the *EASY FROST* can not be cut, jointed or overlapped.

Notes: control unit C2000 works only when connected to both the C2000-SUG and C2000-STG sensors.

# MCA 8

**Self-regulating** cable for tracing roofs, gutters and/or downpipes.

**Prevents**

The formation of ice inside gutters and downspouts, snow accumulation and ice on roofs, the development of infiltrations along façades, the development of ice sticks along gutters and roof ends.

**Avoiding**

Gutter breaking under the weight of snow, bursting and fracturing of drainpipes due to water freezing, damaged caused by a lack of draining caused by drain clogging, damage to persons or property caused by falling ice sticks, damage to persons or property caused by possible snow slides off rooves from roof edges.

Product	In air 0°C Power (W/m)	In chilly water Power (W/m)	Maximum cable length with starting temperature of -10°C through a switchgear (*) of		
			16 A	20 A	30 A
MCA8	24	40	40 m	50 m	90 m

\*Switchgear with "C" characteristic, having a differential protection of 30 mA

Notes: the gutter cable is suspended along the down side of the drain pipes with accessory MCA-SUP. The cable is self-supporting up to 25 m vertical sections; in addition, an extra MCA-SUP accessory is provided for every 25 m, to which the cable is secured.

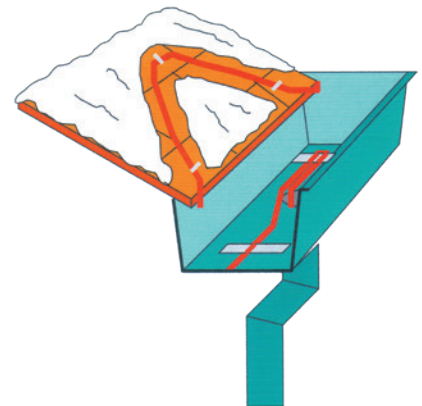

The image shows gutter installation, the input of cable in a downpipe and tracking of a roof pitch.



## Centralina e accessori di collegamento per MCA 8



**C2000**  
The C2000 control unit, to be completed with the C2000-SR temperature, snow and humidity sensor (sensor to be placed flush with the ramp and to be ordered separately from the control unit), activating the power contactor, gives consent to start the system only when low temperature and snow or ice are present simultaneously, optimising energy consumption.

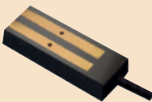

**C2000-SUG**  
Ice and snow sensor.



**C2000-STG**  
Temperature sensor.

Notes: control unit C2000 works only when connected to both the C2000-SUG and C2000-STG sensors.



**MCA Universal IP68**

- Connection kit integrated with the terminal box.
- Non-powered side terminal kit.
- Joint Kit.



**MCA-Y**  
Branch Kit.



**MCA-BOX3 / 4**  
Connection boxes between heating cables or heating and power cables.

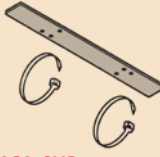

**MCA-SUP**  
Support device.

For other accessories see page 229



埃利亚斯

# HEATING CABLES COMFORT HOUSE

---

## FLOORING

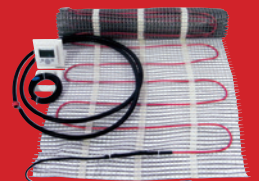

EASY FLOOR

---

## MIRROR



EASY MIRROR

---

## CEILING



WARM-UP

**COMFORT HOUSE**

PRIMARY, SECONDARY  
OR FLOORING COMFORT HEATING SYSTEMS.

Heating mats and intelligent timed thermostat: Raytech intelligent systems for primary, secondary and flooring heating comfort for homes, offices, kindergartens, schools and hospitals.

Combining the total reliability of the Raytech mat system with the RID microprocessor intelligent thermostat, it is possible to autonomously control all space heating parameters, as a primary means in less cold months and as a secondary means together with a more traditional system, and for comfort heating in bathrooms, kitchens, living rooms and children's bedrooms. After the first programming of the RID timed thermostat, you are free to forget about the system, which will run itself, ensuring optimal conditions.



**EASY FLOOR**

The kit is composed of:

- Heating mat complete with cold tail
- RID microprocessor intelligent room timed thermostat complete with sensor
- Corrugated pipe for positioning

**Notes:** -ST type kits are supplied without a RID room timed thermostat

**CHARACTERISTICS**

- **Mat power:** 150 W m<sup>2</sup>
- **Power supply:** 230 V ~ 50Hz
- **Thickness of the mat:** 5 mm
- **Min. temperature of installation:** + 5°C
- **Max. working temperature:** + 70°C
- **Cold cable (power supply):**  
length : ~ 3,50 meters
- **Type of heating cable:**  
2 conductors, shielded
- **Heating cable dimensions:** ~ Ø 5 mm
- **Heating cable power:** : ~ 10 W/m
- **Insulation:** XLPE
- **Outer sheath:** PVC
- **Marking:** CE



**ATTENTION:** since it is a constant power cable, the *EASY FLOOR* can not be cut, jointed or overlapped.

**EASY FLOOR**

Heating mat for the intelligent tracing of tile, marble, floors, etc.

The Easy Floor mat is laid directly on a layer of thermal insulation that coats the floor finished with concrete, and then buried in self-levelling concrete and covered with tiles. The flooring tracing mats are supplied in standard widths of 50 cm, power 150 W/m<sup>2</sup>.

Product	Width (m)	Length (m)	Power (W)
Easy Floor 2	0,5	2	150
Easy Floor 3	0,5	3	225
Easy Floor 4	0,5	4	300
Easy Floor 2-ST	0,5	2	150
Easy Floor 3-ST	0,5	3	225
Easy Floor 4-ST	0,5 </td <td>4</td> <td>300</td>	4	300

Other sizes available upon request.

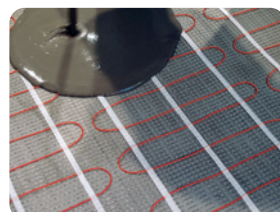

## RID RAYTECH INTELLIGENT DISPLAY

Intelligent room timed thermostat.

The RID (Raytech Intelligent Display) microprocessor room timed thermostat is simple to use, thanks to its step-by-step programming guide. The easy to read display supplies a complete explanation of set parameters after 10 seconds.

The RID autonomously controls all room functions, with no need for extra operations. Weekly programming makes it possible to take into account the set temperature to be maintained, the type and thickness of the flooring, temperature limits not to be exceeded, modes for increasing temperature, etc.

This device is equipped with an anti-freeze function when the house is not inhabited, a block for untimely interventions (for example children) and communicates any operating failures to the appropriate alarms.



Sensor	Included with the kit
Temperature range	+5 / +50°C
Temperature limit	+5 / +55°C
Start Up Programme	Automatic, self learning
Manual	0,1-10°C
Room temperature	0 / +40°C
Differential On/Off	Standard 0,4°C Adjustable 0,1-1°C
Power supply	230 V / 50-60 Hz
Self-consumption	5 W
Max output current	16 A (3400 W/220 V)

Product	(mm)
RID room thermostat	85 x 85 x 45

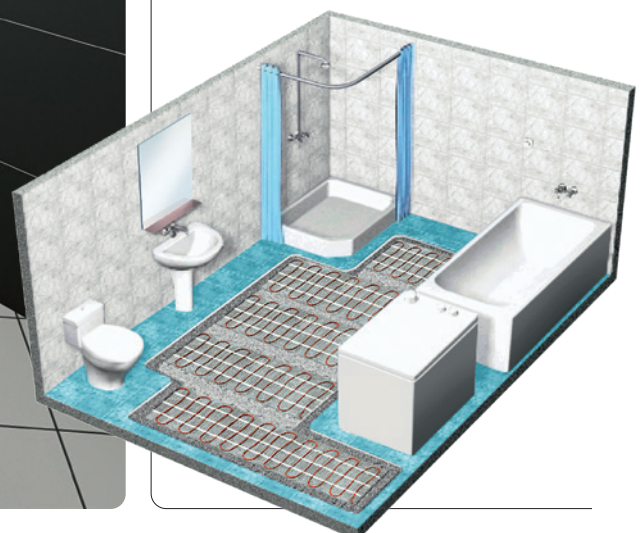

# EASY MIRROR

Self-adhesive heating sheet.

No more fogged mirrors after a shower or bath! Easy Mirror, the self-adhering heating sheet to be applied on the back of the mirror and connected to the mains, eliminates this problem! Powered 230V, double insulated in accordance with safety regulations. Brings the surface of the mirror to 30°C in about 3-5 minutes, removing the film of moisture. Easy Mirror sheets are packaged with a sheet of laminated aluminium on polyester, with double insulation made with 4 more sheets of vulcanised polyester, completely sealed against water.

- Ideal for bathrooms, saunas, kitchens, private homes, Hotels, gyms and sports facilities



Product	Sheet dimensions (cm)	Power (W)
Easy Mirror 35	Ø 35	50
Easy Mirror 36/50	36 x 50	50



### Installation Sequence

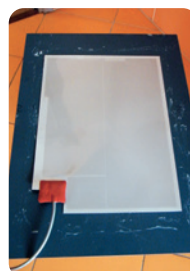
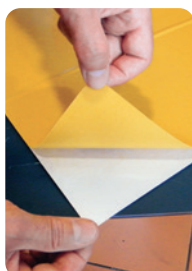

# warm up

Ceiling heating panels



Heat where you want it, when you want it



The ideal solution for all low thermal comfort environments.



## WARM UP

### Ceiling heating panels.

WARM-UP ceiling heating panels by Raytech can be installed invisibly and built into the ceiling of any home, office, showroom, workshop, greenhouse, camper vans etc., maximising space and freeing up wall space. Their positioning does not require any invasive procedures on the walls of the room, and their electrical connection is extremely simple. They can be installed, possibly placing them at the points where maximum thermal efficiency is required, with any mounting system: hung with chains, flush mounted, or recessed in false ceilings, always easily and quickly. The type of heating, based on infrared radiation, which makes it similar to solar radiation, is safe and unharmed, quick, efficient and extremely comfortable.

### Why choose the Warm-Up System?

- It is installed without requiring any invasive procedures to be carried out on the structures of the house.
- It is easily uninstalled for re-use in another context.
- Its radiated heat is safe, with no air movement, and does not dirty the walls and room.
- It is used for primary heating and for secondary heating as an integrative system, and optimises and reduces heating costs thanks to the RID-WL thermostat.

### An ideally integrated invisible system that can also be decorative!



VERANDAS



PREFABRICATED BUILDINGS

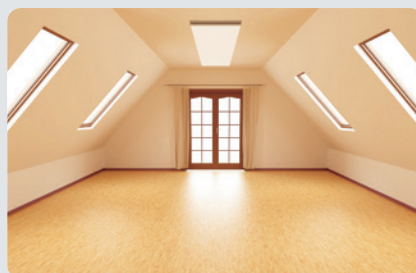

EXHIBITION SPACES



GAZEBOS

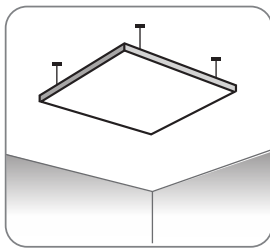

SUSPENDED

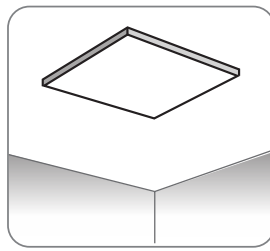
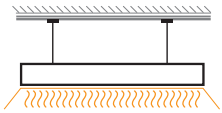

FIXED

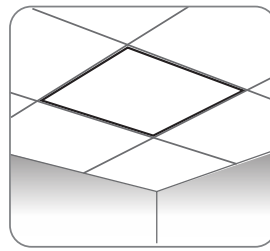

ENCASED

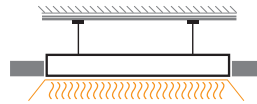

Product	Colour	Power	Dimensions (mm)
Warm Up 1	White, Paintable	300 W	590 x 590 x 40
Warm Up 2		600 W	1190 x 590 x 40

### What Are the Benefits to the System compared to others?

- Heating is immediate, in just a few minutes.
- It leaves room walls free because it is installed on the ceiling, flush mounted or recessed in false ceilings.
- It does not pollute, as it does not use gas or hydrocarbons.
- It optimises heating and reduces costs.
- Unlike other types of heating systems, it does not require maintenance!
- It uses the energy produced by photovoltaic systems, reducing heating costs.
- It can be coloured, and is therefore easily camouflaged or used as a decorative element.

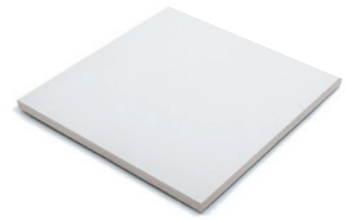

Controlled by a timed thermostat or a power regulator, they reduce consumption to a minimum.

**Class 2**  
**degree of protection IP44**

**Power required for comfort heating:**  
about 60W/m<sup>2</sup>

(one Warm Up 1 panel every 5m<sup>2</sup>)

**For primary heating with well-insulated walls:**  
about 150W/m<sup>2</sup>



STORES



OFFICES



WAREHOUSES - GARAGES



HOMES





**Temperature accuracy:** 0,1°C  
**Field of operation:** from 0°C to +40°C  
**Field of temperature:** from 5°C to +35°C  
**Power supply:** 2 AAA 1.5 V batteries  
**Degree of protection:** IP30  
**Frequency:** 868 MHz  
**Powered receiver:** 230 V, 50 Hz  
**Relay range:** 8 A  
**Range in distance:**  
 100 m outdoors, 30 m indoors

Programmable in 30 minute blocks  
 9 pre-installed programmes and  
 4 user-set programmes  
 "Self-learning" temperature control  
 Child lock  
 Low battery alarm  
 Unlimited programme memory  
 in the case of discharged batteries

## WARM UP ACCESSORIES

### RID-WL

Digital wireless timed thermostat.

Raytech has established the innovative WIRELESS RID-WL TIMED ROOM THERMOSTAT for maximum efficiency and speed and ease of installation. This system combines well-known reliability and control of environmental parameters of the system RID with a wireless connection.

The RID-WL, which operates in radio frequency, allows non-invasive installation in any environment, both for new installations and those related to renovations, or to reinforce an existing primary system.

The RID-WL is coupled with its own receiver, tuned to the frequency of its own thermostat (exclusive signal), which is able to control an ampacity of 8 A.

RID-WL, since it is not wired, it can be moved within the range of use and positioned where controlling the parameters is important.

It is equipped with an easy to read backlit LCD screen and is programmable and provided with a built-in internal sensor, but can be connected to a separate sensor, for example on the floor.

Product	Description
RID-WL	Timed thermostat including receiver



**Degree of protection:** IP30  
**Frequency:** 868 MHz  
**Powered receiver:** 230 V, 50 Hz  
**Relay range:** 8 A  
**Range in distance:**  
 100 m outdoors, 30 m indoors

### ADDITIONAL RELAY DEVICE

Additional relay device, with a maximum of 6 devices which can be controlled by the same RID-WL timed thermostat.

Product	Description
RID-WL-R	Additional receiver for loads greater than 8 A

**HEATING CABLES  
SELF-REGULATING  
ACCESSORIES**



## ACCESSORIES FOR SELF-REGULATING HEATING CABLES (MCA, MCA-I-PF, MCA-I-GF, MCA-I-FF)

### CONNECTION ACCESSORY



**MCA UNIVERSAL IP68**  
Pre-filled gel joint



**MCA BOX**  
Pre-filled gel boxes

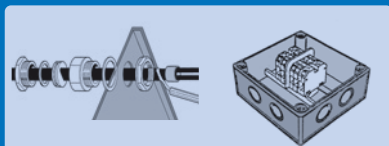

**MCA-PC + MCA-SG**  
Connection kit + Box  
with terminal strip

### DERIVATION ACCESSORY



**MCA Y**  
Branch joint



**MCA BOX**  
Pre-filled gel boxes

### TERMINATION ACCESSORY



**MCA UNIVERSAL IP68**  
Pre-filled gel joint

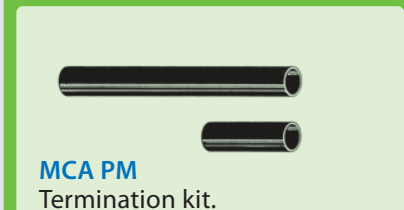

**MCA PM**  
Termination kit.

AT LEAST ONE CONNECTION ACCESSORY AND ONE TERMINATION ACCESSORY ARE REQUIRED FOR EACH SECTION OF HEATING CABLE

CONNECTION  
ACCESSORY

TERMINATION  
ACCESSORY

**L max: maximum length for each section**  
Refer to the ELECTRIC DIMENSIONING table on catalogue or project

IN CASE OF NEED TO MAKE DERIVATIONS, IT IS POSSIBLE TO USE THE RELEVANT ACCESSORIES;  
A TERMINATION ACCESSORY IS THEN NEEDED FOR EACH BRANCH.

CONNECTION  
ACCESSORY

L<sub>1</sub>

DERIVATION  
ACCESSORY

L<sub>2</sub>

DERIVATION  
ACCESSORY

L<sub>N</sub>

TERMINATION  
ACCESSORY

L<sub>D1</sub>

TERMINATION  
ACCESSORY

L<sub>DN</sub>

TERMINATION  
ACCESSORY

The sum of the lengths of the sections under a single power supply must be less than L<sub>max</sub>  
(please refer to the ELECTRIC DIMENSIONING table on catalogue or project)

$$L_1 + L_2 + L_{D1} + \dots + L_{DN} + L_N < L_{max}$$

# MCA UNIVERSAL IP68 MCA-Y

Universal accessory for heating cable.

A revolutionary accessory is now available that is suitable for any type of self regulating heating cable either with or without screening. Its versatility provides a reliable unique solution unavailable elsewhere in the market. It has no shelf life and no tools are required during installation (including blow torches).



## MCA UNIVERSAL IP68

Straight joint between Heating cables



Connection  
termination to  
the power cable



Pot end

## MCA Y

Branch joint

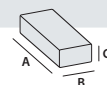

Product	Kit Composition	A x B x C (mm)
MCA Universal IP68	3 screw connectors to connect to the power cable or another heating cable	125 x 43 x 35
MCA-Y	3 screw connectors for branch connections between heating cables	160 x 75 x 37

### Electrical:

CEI EN 50393 e CEI 20-33  
(Notes: with testing under water head  
and water between the cable cores),  
in Class 2

### Flame non propagation:

CEI 20-35, IEC 60332-1 and HD 405-1  
(as applicable)

- Versatile and ready to use
- No need for tools
- Without heating
- Can be installed at any temperature
- Can be used directly underground
- Very compact
- Re-enterable
- Flame retardant
- The connections are automatically blocked when the joint is closed
- Screw connectors available with the kit
- Can be used underwater
- Pre-filled with a gel that is not-classified as hazardous under the CLP Directive and with no shelf life.

# MCA-BOX

## PRE-FILLED GEL CONNECTION BOXES FOR HEATING CABLES.

Boxes for single or multiple connections either between heating cables or heating and power cables. Ready to use, pre-filled with gel, complete with terminal block and screws, they allow the connection between heating cables and between heating cables and power cables, ensuring IP68 and IP69K degree of protection. They are suitable for power cables from 8 to 18 mm diameter and/or for power supplies with insulated wires in conduits of 16, 20, 25 and 32 mm diameter. MCA BOX is essential in damp environments and in areas subject to condensation or flooding. Available as either 3 or 4 entry in order to satisfy any installation requirement.

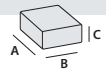

Product	Kit composition	A x B x C (mm)
MCA BOX 3	Gel-prefilled box Terminal block 3 x 6 mm <sup>2</sup> + adaptors	90 x 90 x 45
MCA BOX 4	Gel-prefilled box Terminal block 4 x 6 mm <sup>2</sup> + adaptors	120 x 100 x 45

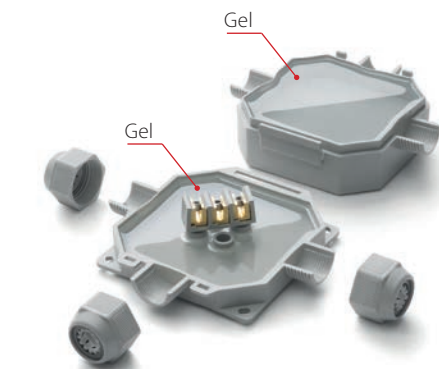

MCA BOX 3

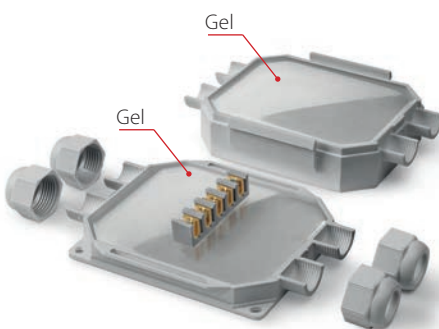
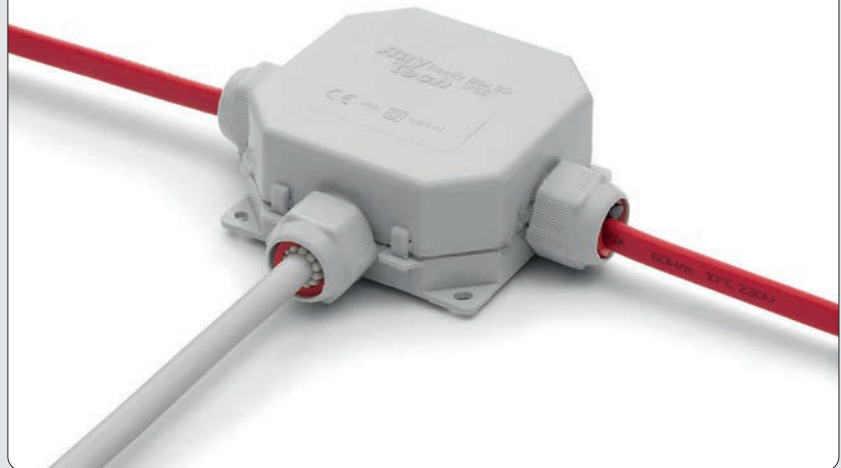

MCA BOX 4



**MCA-PC****CONNECTION KIT.**

Supply side termination allowing connections to a terminal box.  
Made of cold-shrink components and also a dedicated cable gland.  
One for each cable.

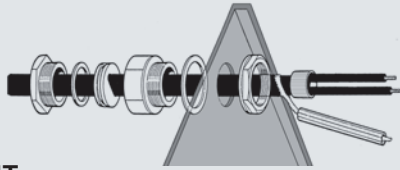
**MCA-AL****THERMAL INSULATION PASS-THROUGH.**

It allows the cable to pass through the metallic covering of the thermal insulation, avoiding abrasions and the moisture or water entry under the covering.  
It contains cable gland and fixing plate.  
One kit for each cable.

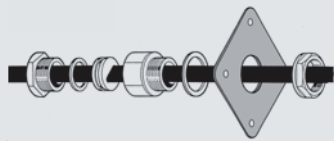
**MCA-PRESS****CABLE GLAND.**

To allow the cable to enter in boxes, to pass through walls etc.  
One kit per cable.

**MCA-SG****BOX.**

Box with IP55 degree of protection, complete of terminals. It allows the entry of 1 or more heating cables, or to branch a cable from a main tracing, or to joint cable lengths. Cables inside the box shall be MCA-PC terminated.

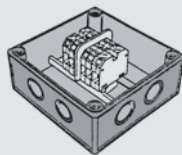
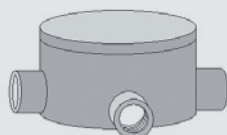
**GUAT 26****CONNECTION KIT FOR CLASSIFIED AREA.****MCA-PM****TERMINATION KIT.**

For insulating and matching the cable ends. Made from cold-shrink components.  
One kit for each termination.

**MCA-GL****JOINT KIT.**

To joint cable ends or to repair damaged cables.  
It contains all the components required, including connectors.  
One kit for each cable.

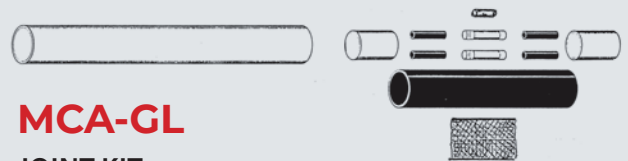
**MCA-SUP****SUPPORT DEVICE FOR GUTTERS AND DOWN PIPES.**

It supports and fixes the cable in gutters and downpipes. In large gutters, requiring 2 cables laid longitudinally, it maintains the cable at the right distance.

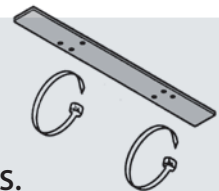
**MCA-FV****GLASS FIBER TAPE.**

To fix the cable to the pipe, 3 turns every 0,3 m of pipe.  
Self adhesive, in 50 m rolls.

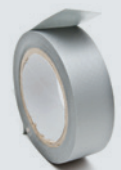
**MCA-ALL75****ALUMINIUM SELF ADHESIVE TAPE 75 MM WIDTH.**

For cable fixing, in 50 m rolls.

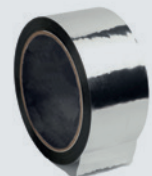
**MCA-EA****WARNING LABEL.**

To be applied for warning over traced items.

WARNING  
ELECTRIC  
TRANCING

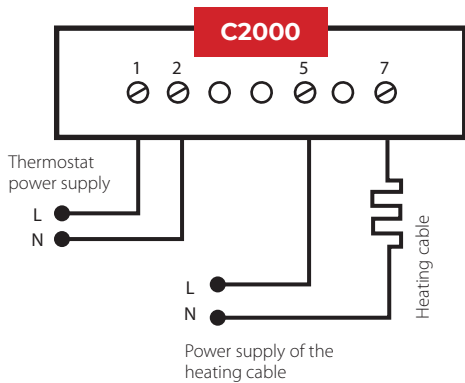

## CONTROL UNIT C2000

### C 2000 CONTROL UNIT FOR TEMPERATURE AND HUMIDITY.

The C2000 control unit and relative sensors are suitable for the tracing with both self-regulating cables and constant power cables. The unit allows you to power the system only when low temperatures and humid surfaces (snow - ice, etc.) are present simultaneously.



#### Signalling lamps

- ON voltage
- RELAY cable on power
- MOIST humidity presence
- TEMP the temperature is lower than the fixed

**Voltage:** 230V c.a. +/- 10% 50/60Hz  
**Output:** N° 1 relays  
**Switching capacity:** 16A (3600 W)  
**Differential ON/OFF:** 0,4°C  
**Temperature Range:** 0-10°C  
**After run time:** 1-6 hours  
**Protection degree:** IP20  
**Dimensions:** 85 x 42 x 48,8 mm  
**Weight:** 252 gr  
**Room temperature:** 0/50°C

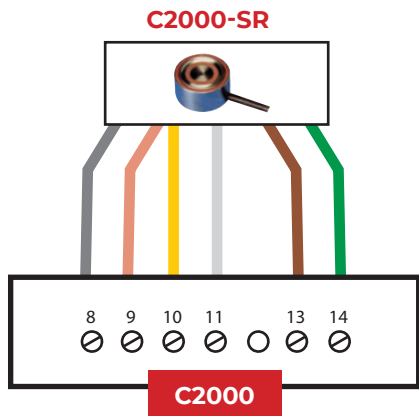

## C2000-SR

### HUMIDITY AND TEMPERATURE SENSOR FOR RAMPS AND STAIRS.

**Dimensions:** h 32 mm - Ø 60 mm  
**Protection degree:** IP68  
**Ambient temperature:** -20°C / +70°C  
**Connecting cable:** 6x1,5 mm<sup>2</sup>, length. 10 m (possible increase up to 200 m)

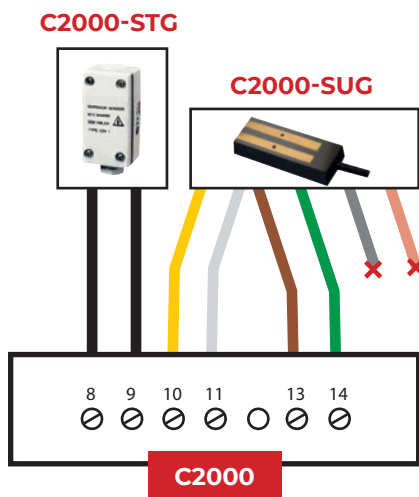
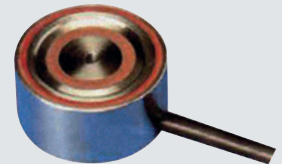

## C2000-SUG

### ICE AND SNOW SENSOR FOR GUTTERS.

**Dimensions:** 105 x 30 x 10mm  
**Protection degree:** IP68  
**Ambient temperature:** -20°C / +70°C  
**Connecting cable:** 4x1,5 mm<sup>2</sup>, length 10 m (possible increase up to 200 m)

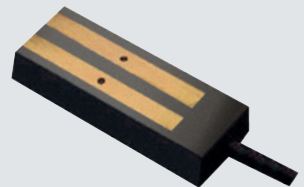

## C2000-STG

### TEMPERATURE SENSOR FOR GUTTERS.

**Dimensions:** 86 x 45 x 35 mm  
**Protection degree:** IP55  
**Ambient temperature:** -20°C / 70°C  
**Connecting cable:** not included



## T2000 THERMOSTAT

### ON/OFF THERMOSTAT – P.I.D. 2 OUTPUTS WITH TEMPERATURE ALARM MANAGEMENT.

T2000 digital thermostats, complete with probe included in the kit, are suitable for control both in heating, maintenance and refrigeration.

Suitable for rear panel installation, on DIN guide, they are compact and they have controls and displays arranged frontally.



#### Characteristics T2000 thermostat

- **Measuring Range:** -40 a +105°C
- **Degree of protection:** IP40 (front)
- **2 outputs** with unipolar relay in deviation
- **Power supply:** 230 V a.c. ± 10 %
- **Contact capacity:** 240 Vac , 16 A (resistive); 4 A (inductive),
- **Self-consumption:** 3 W
- **Control:** ON/OFF or PID - Output ON or OFF depending on the incoming temperature, set point and hysteresis values set. The hysteresis is the value of the deviation from the set point that determines the reactivation of the output.
- **Alarm management:** output 2
- **Proportional control and integrative proportional**
- **Minimum or maximum set point limits**
- **Operating temperature:** -10 a +50°C
- **Dimensions:** L 71 x H 98 x W 61

#### CONNECTION DIAGRAM

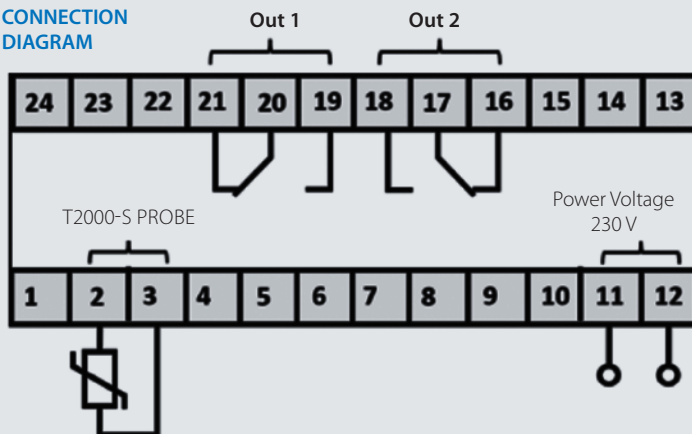

## T2000-S PROBE

(in thermostat kit included)

#### T2000 probe features

- **Type:** NTC10k
- **Measuring Range:** -40 a +105 °C
- **Precision** ± 1,5 K a 25 °C
- **Probe length:** 2 m
- **Connection cable:** bipolar (2 x 0,4 mm<sup>2</sup>)
- **Tip Dimensions:** Ø 6 x 34 mm
- **Degree of protection:** IP67



## STEPS AND WALKWAYS

Data request form for the heating tracing design

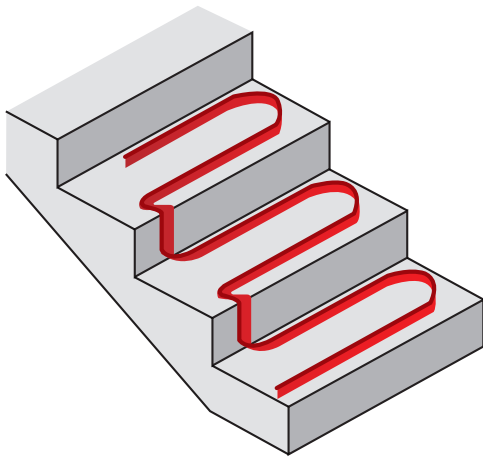

## GUTTERS AND DOWNSPOUTS

Data request form for the heating tracing design

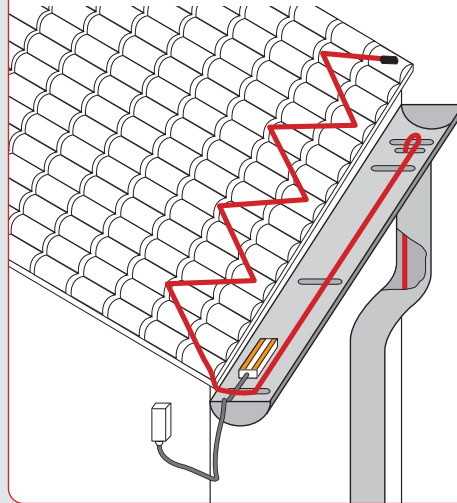
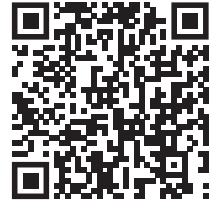

## RAMP

Data request form for the heating tracing design

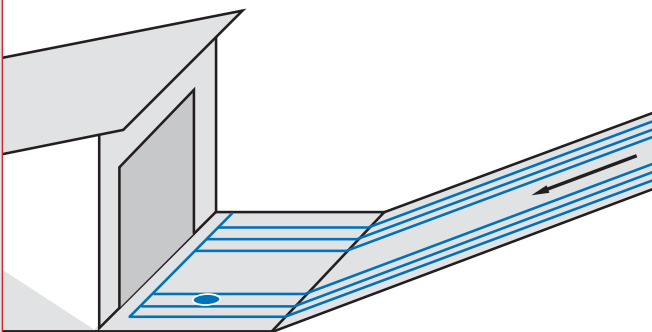

## TERRACE BALCONY AND ROOFS

Data request form for the heating tracing design

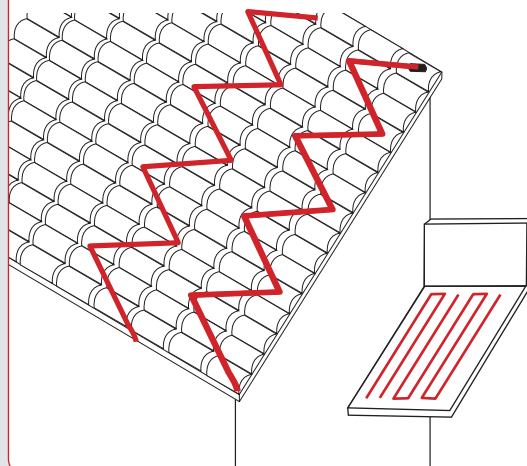

## PIPING

Data request form  
for the **heating**  
tracing design

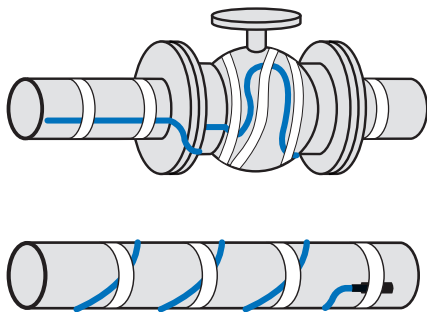
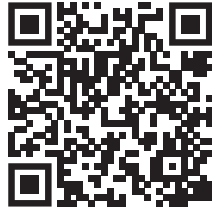

## SILOS AND TANKS

Data request form  
for the **heating**  
tracing design

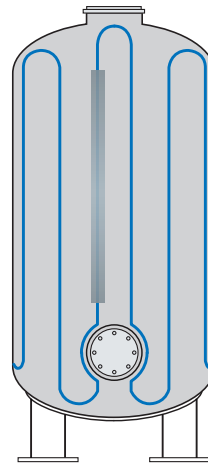
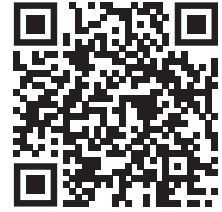

## COMFORT - INDOOR FLOORS

Data request form for the **heating** tracing design

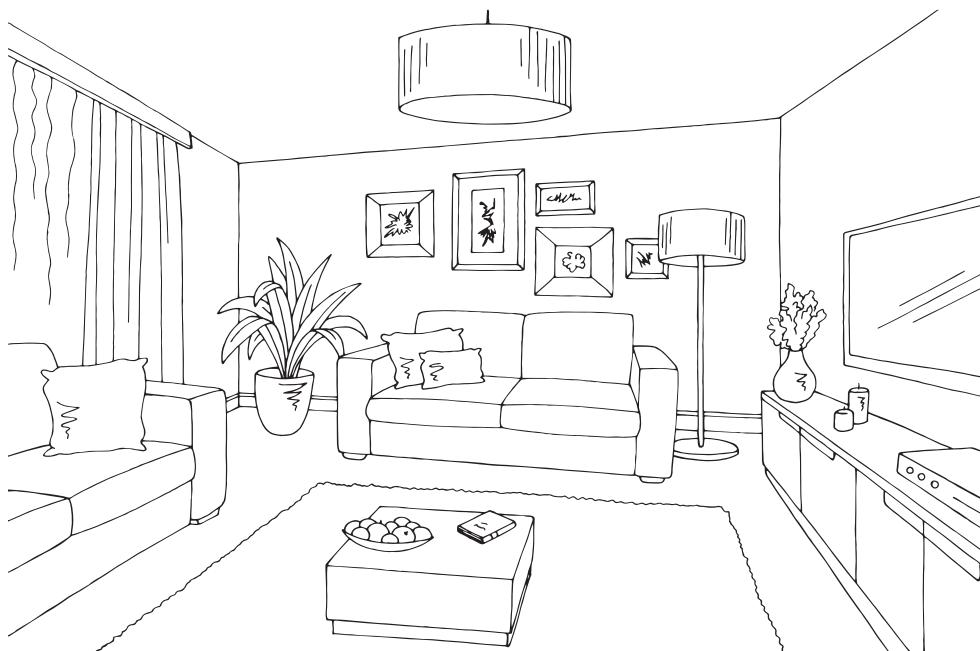



## CERTIFICATE OF CORRECT EXECUTION OF INSULATION RESISTANCE MEASUREMENT TESTS AND VERIFICATION OF SYSTEM FUNCTIONALITY, FOR EACH SECTION OF **CONSTANT POWER HEATING CABLE.**

To be filled in by the electrician installer

Customer: \_\_\_\_\_

Place of installation: \_\_\_\_\_

Tracing number: \_\_\_\_\_

Tracing type:  Ramps  Walkways  Terrace  Steps  
 Gutter  Roofs  Piping  Silos

Heating cable **INSTALLED BY**

Company: \_\_\_\_\_

Operator: \_\_\_\_\_

Date: \_\_\_\_\_

### Fill in the table for each heating cable section

Heating cable section n. \_\_\_\_\_

Heating cable or mat type (code) \_\_\_\_\_

Heating cable / mat length (m) \_\_\_\_\_

#### RESISTANCE AND INSULATION TESTS (with 500 Vcc instrument)

JUST EXTRACTED THE  
CABLE FROM THE  
PACKAGE  
Measure A

AFTER CABLE LAYING  
ON THE SCREED OR  
PIPE  
Measure B

AFTER APPLICATION OF  
THE COVERING LAYER OR  
THERMAL INSULATION  
Measure C

Between resistance wires 1 and 2 (Ohm)			
Between wire 1 and ground (must be infinite)			
Between wire 2 and ground (must be infinite)			

#### VERIFICATION OF CABLE FUNCTIONALITY, feeding the cable section to the nominal voltage to verify the suitability of the connection

AFTER CABLE  
LAYING  
Measure B

AFTER APPLICATION OF THE COVERING  
LAYER OR THERMAL INSULATION  
Measure C

Current absorption (A)		
------------------------	--	--

#### CABLE INSTALLED AND TESTED BY:

Company

Operator

Date

Stamp end Signature

Keep carefully the control certificate. If necessary, repeat the measurements during the periodic maintenance checks.